



Catalogue

Version 2019

2019 EN



ZCC Cutting Tools Europe GmbH

your Partner | your Value

Parting & grooving

Product overview	A338-A339
System overview	A340-A343
Chip breaker overview	A344-A345
Grade overview	A346-A347
Application fields of grades	A348-A350
System code – inserts	A352
Inserts	A353-A367
System code – inserts – QC series	A368
Inserts – QC series	A369-A373
System code – tool holders	A374-A376
Tool holders	A377-A397
System code – tool holders – QC series	A398
Tool holders – QC series	A399-A401
Recommended cutting data	A402-A404
Technical Information	A455

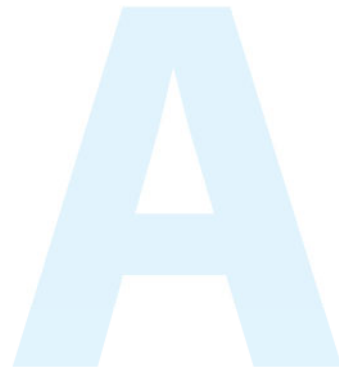

A

Turning

B

Milling

C

Drilling

D

Technical
Information

E





Index

A

Turning





Parting & grooving inserts

Double sided





					
ZT*D-MM	ZT*D-MG	ZT**-EG	ZP*D-MG	ZP*D-MG-R/L	
2-8	2.5-6	1-6.5	2.5-6	2.35-2.85	Width
A353	A357	A359	A354	A356	Page

B

Milling

				
ZR*D-MG	ZR*D-EG	ZR*D-LH	ZILD-LC	
2.5-6	3-6	6-8	8	Width
A362	A363	A366	A367	Page



Single sided

				
ZT*S-MG	ZP*S-MG	ZIMF-NM	ZIGQ-NM	
5-6	2.5-6	3-6	3-6	Width
A358	A355	A364	A365	Page

C

Drilling

Three cutting edges

		
QC**R/L	QC**R/L***R	
0.75-4.8	1-4	Width
A369	A372	Page





D







Technical Information

E

Index

External tool holders

				
GQC**R/L	QE**R/L	QE*S**N	QE*SR/L	QECDR/L
A399	A377	A383	A382	A380

						
QF**R/L	QF**RR/LL	QF*DR/L	QF*SRR/LL	QFHSDR/L	QX*DR/L	QZS*
A385	A387	A390	A389	A392	A381	A384

Boring bars

		
C***-Q*DR/L	C40X-Q*DR/L	S**-QC**R/L
A395	A394	A400

A

Turning

B

Milling

C

Drilling



D

Technical Information





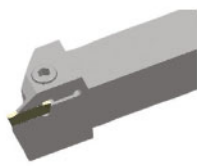

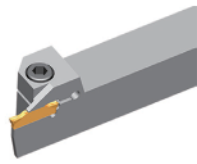
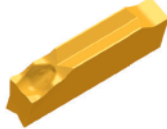
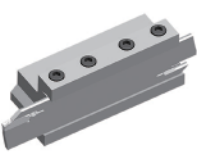
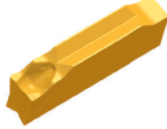
E

Index

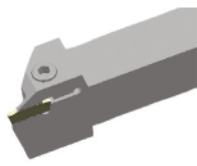
External machining - Parting

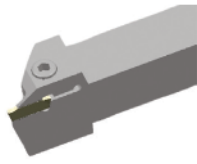
Product	Tool holders	Inserts	Tool features an parameters	Page
QE*D*/R/L		 ZP**D*	<ul style="list-style-type: none"> – Inserts with 3D chip breakers for low cutting forces and good chip control. – Max. parting diameter 60.0 mm – Double edged 	A377
QE*S*/R/L		 ZP*S*	<ul style="list-style-type: none"> – Inserts with three different chip breakers for low cutting forces and good chip control. – Max. parting diameter 60.0 mm – Double edged 	A382
QZ**+QE**		 ZP*S**	<ul style="list-style-type: none"> – Variable overhang, also for in greater grooving depths. – Max. parting diameter 120.0 mm – Single edge 	A384

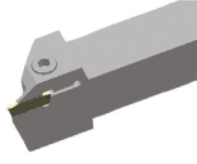
External machining - Grooving an precise grooving







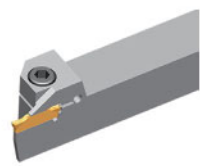
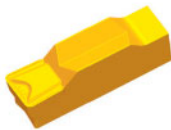

Product	Tool holders	Inserts	Tool features an parameters	Page
QE*D*/R/L		 ZT*D**	<ul style="list-style-type: none"> – With this universal tooling system, using the different inserts, applications like parting, grooving, profiling and turning are possible – Max. groove depth 30.0 mm – Double edged 	A377
QE*D*/R/L		 ZR*D*	<ul style="list-style-type: none"> – With this universal tooling system, using the different inserts, applications like parting, grooving, profiling and turning are possible – Max. groove depth 30.0 mm – Double edged 	A377
QE*D*/R/L		 ZT*D**-EG	<ul style="list-style-type: none"> – Ground inserts for precision grooving. – Cutting edge width can be any size between 1.0–6.5 mm according to customers requirements. 	A377

A Turning
B Milling
C Drilling
D Technical Information
E Index

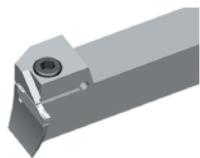

External machining - Grooving an precise grooving

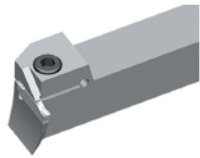
Product	Tool holders	Inserts	Tool features an parameters	Page
QE*S*R/L		 ZT*S*	<ul style="list-style-type: none"> - With this universal tooling system, and by using the different inserts, applications like parting, grooving, profiling and turning are possible - Max. groove depth 30.0 mm - Single edged 	A382

External machining - Axial grooving

Product	Tool holders	Inserts	Tool features an parameters	Page
QF*D*LL-H		 ZT*D**	<ul style="list-style-type: none"> - Tooling system for groove turning and profiling. - Parting diameter 48.0–400.0 mm - Groove depth 10.0–30.0 mm - Double edged 	A385
QF*D*LL-H		 ZR*D**	<ul style="list-style-type: none"> - Tooling system for groove turning and profiling. - Parting diameter 48.0–400.0 mm - Groove depth 10.0–30.0 mm - Double edged 	A385
QF*D*R/L-L		 ZT*D**	<ul style="list-style-type: none"> - Tooling system for groove turning and profiling. - Parting diameter 48.0–400.0 mm - Groove depth 10.0–30.0 mm - 90° tool holder, top clamping - Double edged" 	A390
QF*D*R/L-L		 ZR*D**	<ul style="list-style-type: none"> - Tooling system for groove turning and profiling. - Parting diameter 48.0–400.0 mm - Groove depth 10.0–30.0 mm - 90° tool holder, top clamping - Double edged" 	A390

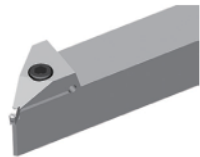
External machining - Undercutting

Product	Tool holders	Inserts	Tool features an parameters	Page
QX*D*		 ZT*D**	<ul style="list-style-type: none"> - Monoblock tool holder positioned at an angle (45°). - Tooling system for undercutting and turning. - Different turning operations like recesses, undercuts and copy turning. - Double edged 	A381

A

Turning

B

Milling

C

Drilling



D

Technical Information

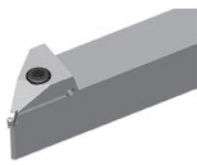

E

Index



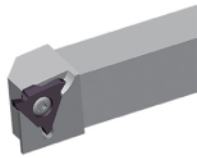

External machining - Undercutting

Product	Tool holders	Inserts	Tool features an parameters	Page
QX*D*		 ZR*D**	<ul style="list-style-type: none"> – Monoblock tool holder positioned at an angle (45°). – Tooling system for undercutting and turning. – Different turning operations like recesses, undercuts and copy turning. – Double edged 	A381



External machining - Grooving

Product	Tool holders	Inserts	Tool features an parameters	Page
GQCR/L		 QC16/22****	<ul style="list-style-type: none"> – Precision ground with high tolerances. – Sharp cutting edge for precise machining. – High efficiency with three cutting edges. – Finishing for groove width between 0.5 mm–4.8 mm – Max. groove depth 5.0 mm – Triple edged 	A399

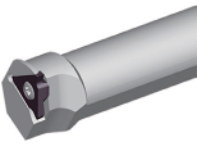

Internal machining - Grooving & turning

Product	Tool holders	Inserts	Tool features an parameters	Page
C*-Q*R/L*		 ZT*D**	<ul style="list-style-type: none"> – Tooling system for groove turning and profiling. – Max. groove depth 13.0 mm – Min. diameter 27.0 mm – Double edged 	A395
C*-Q*R/L*		 ZR*D*	<ul style="list-style-type: none"> – Tooling system for groove turning and profiling. – Max. groove depth 13.0 mm – Min. diameter 27.0 mm – Double edged 	A395



Internal machining - Grooving

Product	Tool holders	Inserts	Tool features an parameters	Page
S***-QC**R/L*		 QC11/16/22****	<ul style="list-style-type: none"> – Fine ground insert for high precision. – Groove width 0.5–4.8 mm – Min. diameter 16.0 mm – Max. groove depth 4.0 mm (Right holder + left insert Left holder + right insert) – Double edged 	A400

Aluminium machining - Facing & longitudinal profile turning

Product	Tool holders	Inserts	Tool features an parameters	Page
C*X-Q*DR/L		 ZR**-LH	<ul style="list-style-type: none"> - Special chip breakers for machining of aluminium. - Sharp and stable cutting edge for continuous and interrupted cut. - Profiling of aluminium rims. - Double edged 	A394

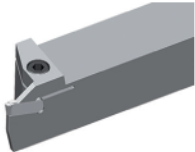
Machining of Heat resistant alloy materials - External machining

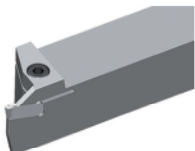
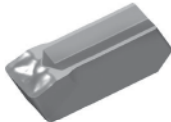
Product	Tool holders	Inserts	Tool features an parameters	Page
QE*S*N		 ZIGQ**	<ul style="list-style-type: none"> - Precision insert with optimised seat and safe clamping. - Insert for heat-resistant alloys and special materials. 	A382
QE*S*N		 ZIMF**	<ul style="list-style-type: none"> - Precision insert with optimised seat and safe clamping. - Insert for heat-resistant alloys and special materials. 	A382

A

Turning

B

Milling

C

Drilling

D

Technical Information

E

Index

A

Turning

Grooving

MM P M K S



Ground chip breaker with straight cutting edge for general machining of steel, stainless steel and heat-resistant alloys. Suitable for grooving, turning and parting.

B

Milling

MG P M K S

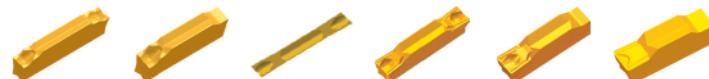

Universal chip breaker for general machining of steel, stainless steel and cast iron. Suitable for grooving, turning and parting.

C

Drilling

MG P M K S



Universal chip breaker with round profile for general machining of steel, stainless steel and cast iron. Suitable for grooving and profiling.

D

Technical Information

EG M P S



Ground precision chip breaker for grooving and turning applications. Suitable for machining of stainless steel. E-tolerance for high repeatability.

EG M P S



Ground precision chip breaker with round profile for grooving and turning applications. Suitable for machining of stainless steel. E-tolerance for high repeatability.

E

Index

NM S

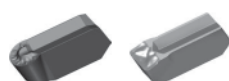

Special chip breaker for machining of heat-resistant materials.

Grooving

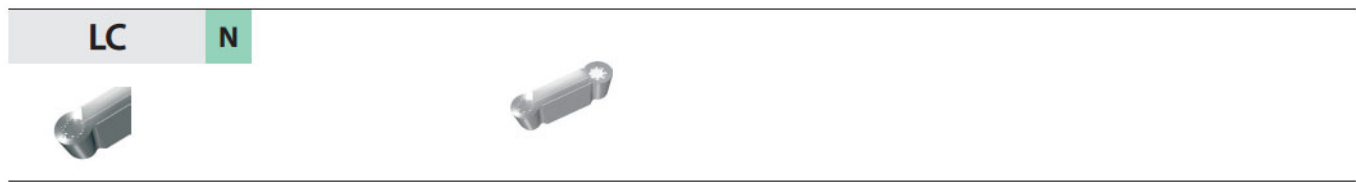

Ground chip breaker for profile and turning applications of non-ferrous metals.



Ground chip breaker for profile and turning applications of non-ferrous metals.

A

Turning

B

Milling

C

Drilling

D

Technical
Information



E

Index

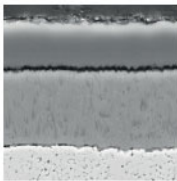
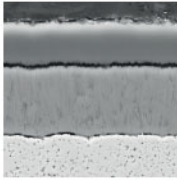
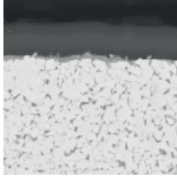
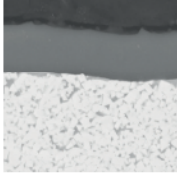
Parting & grooving

Grade	ISO	Micro structure	Grade description
A Turning	YBC152	P10 - P20	 <p>CVD coated P10–P20 carbide grade for finishing to medium operation of steel and casting steel. Outstanding performance under higher cutting speed and temperature with excellent wear resistance.</p>
B Milling	YBC252	P20 - P35	 <p>CVD coated P20–P35 carbide grade for medium operation to roughing of steel and casting steel. Optimal performance of wear resistance and toughness for a wide application field.</p>
D Technical Information	YBG105	S05 - S20	 <p>PVD multilayer coated S05–S20 carbide substrate for finishing to medium application of super alloy material but also stainless steel. Good wear resistance and thermal stability in a wide application field.</p>
YBG202	P10 - P30 M10 - M25	 <p>PVD coated P10–P30/M10–M25 carbide substrate for finishing to medium application of stainless steel and steel (milling). Good wear resistance in a wide application field.</p>	
			YBG205

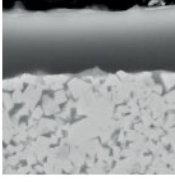
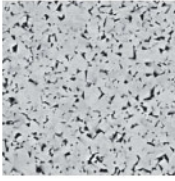
Parting & grooving

Grade	ISO	Micro structure	Grade description
YBG302	P15 - P30 M25 - M40		PVD coated P15–P30/M25–M40 carbide substrate for medium roughing application of stainless steel and steel (milling). Good wear resistance and toughness.
YD101	K05 - K20 N05 - N20		Uncoated K05–K20/N05–N20 carbide substrate for fine to medium application in aluminum and other material.
YD201	K10 - K30 N10 - N30		Uncoated K10–K30/N10–N30 carbide substrate for medium application in aluminum and other material.

A

Turning

B

Milling

C

Drilling

DTechnical
Information**E**

Index

CVD grades for steel, stainless steel and cast iron

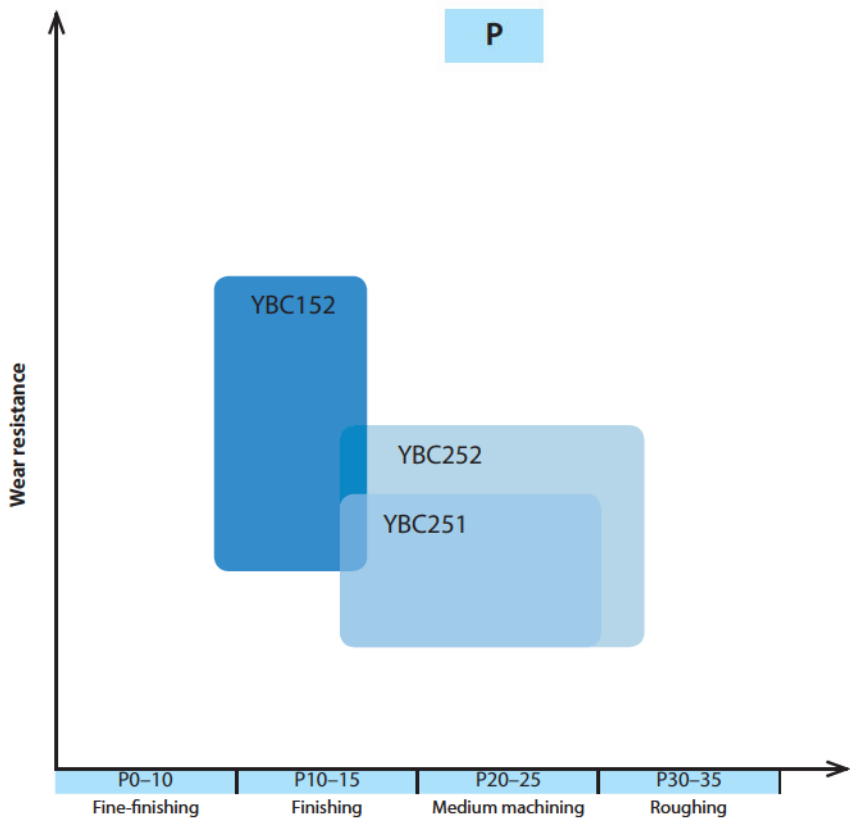

A

Turning

B

Milling

C

Drilling

D

Technical Information

E

Index

PVD grade for stainless steel and heat-resistant alloys

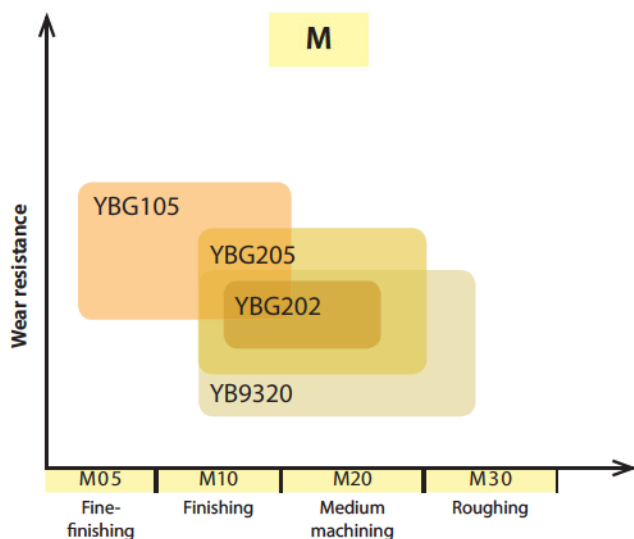

A

Turning

B

Milling

C

Drilling

Turning grades for non-ferrous metals

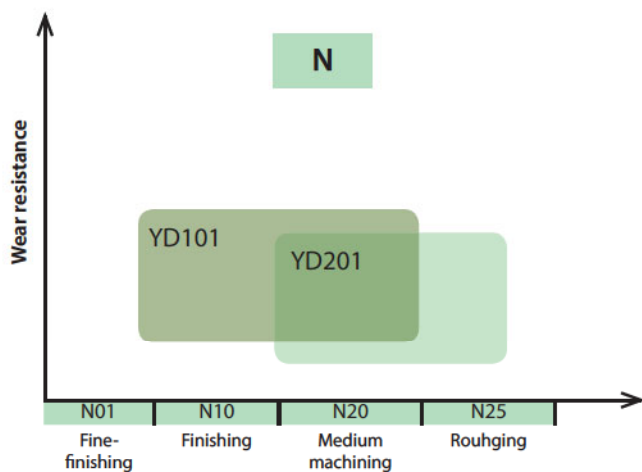

D

Technical Information

E

Index

Application fields of grades – parting & grooving

	ISO	HC ¹ (CVD)	HC ¹ (PVD)	HT	HC ²	Ceramic	HW	CBN	PCD
A Turning	P01								
	P10	YBC152	YBG202						
	P20	YBC251 YBC252	YB9320						
	P30		YBG302						
	P40								
B Milling	M01								
	M10		YBG202						
	M20		YB9320						
	M30		YBG302						
	M40								
C Drilling	K01								
	K10								
	K20								
	K30								
D Technical Information	N01						YD101		
	N10						YD102		
	N20								
	N30								
E Index	S01								
	S10		YBG102						
	S20								
	S30								
F Index	H01								
	H10								
	H20								
	H30								

P	Steel
M	Stainless steel
K	Cast iron

N	Non-ferrous metals
S	Heat-resistant alloys
H	Hardened materials

HC¹	Coated carbide
HT	Uncoated cermet
HC²	Coated cermet
HW	Uncoated carbide

New

MM chip breaker

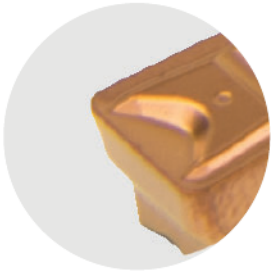

Ground chip breaker in combination with grade YB9320 for general machining of steel, stainless steel and heat-resistant alloys. Suitable for grooving, groove turning and parting.

Width 2.0 mm bis 8.0 mm

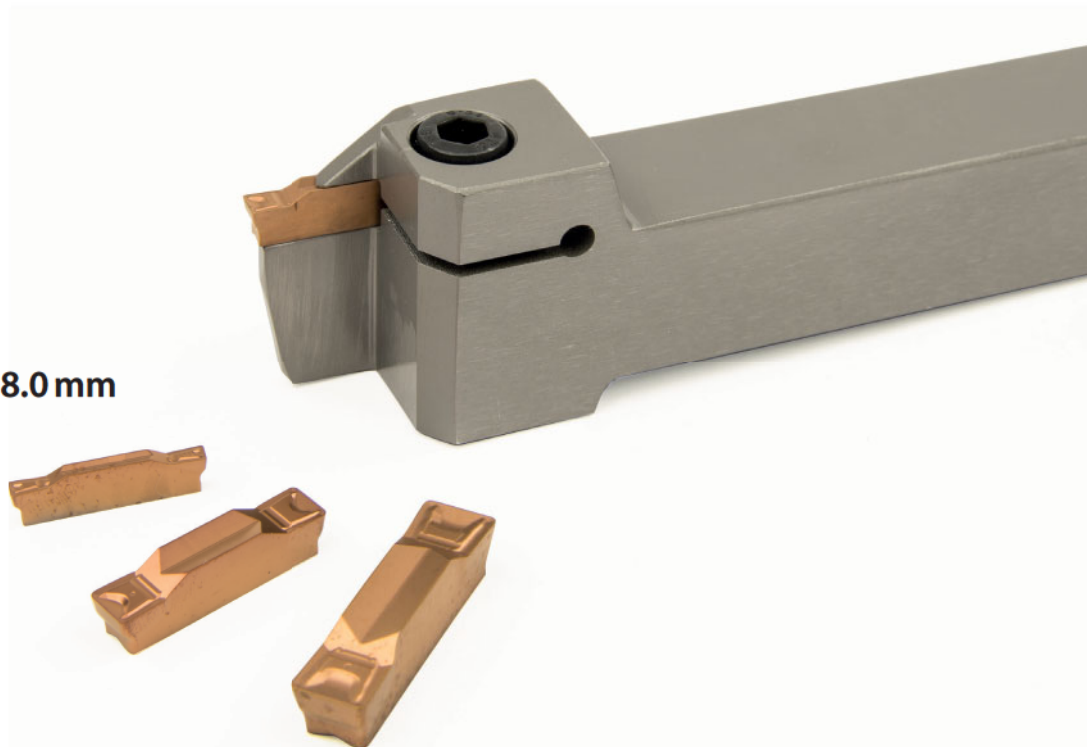

ZP G D 04 04 – M G

1 2 3 4 5 6 7

A

Turning

B

Milling

C

Drilling

D

Technical Information

E

Index

Application	
Code	Description
ZP	Parting
ZT	Grooving & turning
ZR	Form turning

1

Insert seat size [mm]	
Groove width	
Code	Description
B	2,0
E	2,5
F	3,0
G	4,0
H	5,0
K	6,0
L	8,0

2

No. of cutting edges	
Code	Description
S	Single
D	Double

3

Insert thickness S [mm]	
	
Code	S
02	2,0
025	2,5
03	3,0
04	4,0
05	5,0
06	6,0
08	8,0

4

Nose radius r [mm]	
	
Code	r
02	0,2
03	0,3
04	0,4
08	0,8



5

Tolerance class [mm]	
Code	Description
M	±0,13
E	±0,025











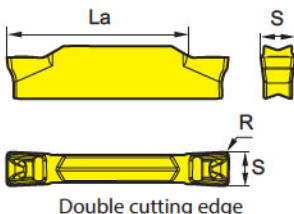





6

Chip breaker	
Code	Description
G	General chip breaker
F	Special chip breaker
M	Straight edge

7

-  Ideal machining conditions
-  Normal machining conditions
-  Unfavourable machining conditions







Parting inserts

ZT** parting & grooving insert (double sided)					HC ¹ (CVD)		HC ¹ (PVD)			HW	
 <p>Double cutting edge</p>	P										
	M										
	K										
	N										
	S										
	H										
ISO	R±0.1	La max	S	f	YBC252 YBC251		YBG105 YBG102 YB9320 YBG205 YBG202 YBG302			YD101 YD201	
	ZTBD02002-MM	0.2	13	2	0,02-0,07			● ● ○ ○			
	ZTED02503-MM	0.3	17	2.5	0,03-0,1			●			
	ZTFD0303-MM	0.3	17	3	0,04-0,13			●			
	ZTGD0404-MM	0.4	22	4	0,06-0,18			●			
	ZTHD0504-MM	0.4	22	5	0,08-0,23			●			
	ZTKD0608-MM	0.8	22	6	0,12-0,27			●			
	ZTLD0808-MM	0.8	28	8	0,13-0,29			● ○			

● Ex stock ○ On demand

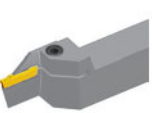
HC¹ Coated carbide
HW Uncoated carbide

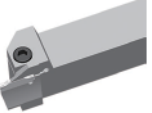
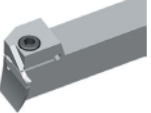
Tool holders

*-QBDR/L	QE*D*R/L	QF*D*R/L-H	QF*D*LL-H	QF*D*RR-H	QF*D*R/L-L	C***-Q*DR/L
						
A395	A377	A385	A387	A387	A390	A395

System code > A352

Grade selection > A350

Technical info > A447

Cutting data > A402



A

Turning

B

Milling

C

Drilling

D

Technical Information



E











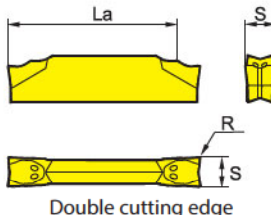

Index

A

Turning



















Parting inserts

-  Ideal machining conditions
-  Normal machining conditions
-  Unfavourable machining conditions

Parting & grooving insert (double sided)		HC ¹ (CVD)		HC ¹ (PVD)		HW		
 <p>Double cutting edge</p>	P							
	M							
	K							
	N							
	S							
H								

B

Milling







ISO	R±0.1	La max	S±0.10	f	YBC252	YBC251	YBG105	YBG102	YBG9320	YBG205	YBG202	YBG302	YD101	YD201
 ZPED02502-MG	0.2	17	2.5	0,03-0,1										
ZPFD0302-MG	0.2	17	3	0,04-0,13										
ZPGD0402-MG	0.2	22	4	0,07-0,18										
ZPHD0503-MG	0.3	22	5	0,1-0,24										
ZPKD0604-MG	0.4	22	6	0,12-0,29										

● Ex stock ○ On demand

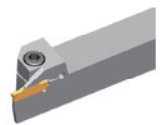
HC¹ Coated carbide
HW Uncoated carbide

C

Drilling

Tool holders					
QE*D*R/L	QF*D*R/L-H	QF*D*LL-H	QF*D*RR-H	QF*D*R/L-L	C***-Q*DR/L
					
A377	A385	A387	A387	A390	A395

D

Technical Information

E

Index

System code > A352

Grade selection > A350

Technical info > A447

Cutting data > A402

- Ideal machining conditions
- Normal machining conditions
- Unfavourable machining conditions

Parting inserts

Parting & grooving insert (single sided)					HC ¹ (CVD)		HC ¹ (PVD)			HW		
<p>Single cutting edge</p>	P											
	M											
	K											
	N											
	S											
	H											
ISO	R±0.1	S±0.10	f	YBC252 YBC251			YBG105 YBG102 YB9320 YBG205 YBG202 YBG302			YD101 YD201		
	ZPES02502-MG	0.2	2.5	0,03-0,1								
	ZPFS0302-MG	0.2	3	0,04-0,13								
	ZPGS0402-MG	0.2	4	0,07-0,18								
	ZPHS0503-MG	0.3	5	0,1-0,24								
	ZPKS0604-MG	0.4	6	0,12-0,29								

● Ex stock ○ On demand

Single sided inserts only for parting blades

HC¹ Coated carbide
HW Uncoated carbide

Tool holders					
QE*S*/R/L	QZ**+QE**	QF*S*LL-H	QF*S*RR-H	QF*S*/R/L-L	QF*S*/R/L-H
A379	A383	A389	A389	A392	A393

System code > A352

Grade selection > A350

Technical info > A447

Cutting data > A402



A

Turning

B

Milling

C

Drilling

D

Technical Information



E











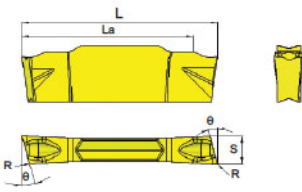





Index

A

Turning

Parting inserts

-  Ideal machining conditions
-  Normal machining conditions
-  Unfavourable machining conditions

ZT** parting & grooving insert (double sided)								HC ¹ (CVD)		HC ¹ (PVD)			HW		
	P														
	M														
	K														
	N														
	S														
	H														
ISO	La max	L	S	θ	R	f	YBC252	YBC251	YBG105	YBG102	YBG205	YBG202	YBG302	YD101	YD201
ZPED02502-MG-6L	17	20	2.35	6°	0.2	0,03-0,08							●		
ZPED02502-MG-6R	17	20	2.35	6°	0.2	0,03-0,08				●		●			
ZPED02502-MG-15L	17	20	2.35	15°	0.2	0,03-0,05							○		
ZPED02502-MG-15R	17	20	2.35	15°	0.2	0,03-0,05						○	○		
ZPFD0302-MG-6L	17	20	2.85	6°	0.2	0,04-0,1				●	●	●			
ZPFD0302-MG-6R	17	20	2.85	6°	0.2	0,04-0,1				●	●	○			
ZPFD0302-MG-15L	17	20	2.85	15°	0.2	0,04-0,08						○	○		
ZPFD0302-MG-15R	17	20	2.85	15°	0.3	0,04-0,08				●	●	○			

B

Milling



C

Drilling

- Ex stock
- On demand

HC¹ Coated carbide
HW Uncoated carbide

Tool holders

QE*D*R/L

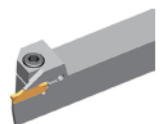

A377

D

Technical Information

E

Index



- Ideal machining conditions
- Normal machining conditions
- Unfavourable machining conditions

Parting inserts

Parting & grooving insert (double sided)					HC ¹ (CVD)		HC ¹ (PVD)			HW					
<p>Double cutting edge</p>					P										
					M										
					K										
					N										
					S										
					H										
ISO	R±0.1	La max	S±0.10	f	YBC252	YBC251		YBG105	YBG102	YB9320	YBG205	YBG202	YBG302	YD101	YD201
ZTED02503-MG	0.3	17	2.5	0,03-0,11											
ZTFD0303-MG	0.3	17	3	0,04-0,14											
ZTGD0404-MG	0.4	22	4	0,07-0,2											
ZTHD0504-MG	0.4	22	5	0,10-0,25											
ZTKD0608-MG	0.8	22	6	0,13-0,30											

● Ex stock ○ On demand

HC¹ Coated carbide
HW Uncoated carbide

Tool holders					
QE*D*R/L	QF*D*R/L-H	QF*D*LL-H	QF*D*RR-H	QF*D*R/L-L	C***-Q*DR/L
A377	A385	A387	A387	A390	A395

System code > A352

Grade selection > A350

Technical info > A447

Cutting data > A402



A

Turning

B

Milling

C

Drilling

D

Technical Information



E











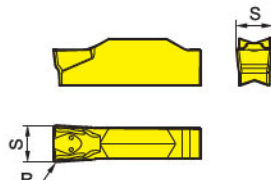





Index

A

Turning



Parting inserts

-  Ideal machining conditions
-  Normal machining conditions
-  Unfavourable machining conditions

Parting & grooving insert (single sided)				HC ¹ (CVD)		HC ¹ (PVD)			HW		
 <p>Single cutting edge</p>	P										
	M										
	K										
	N										
	S										
H											

B

Milling





ISO	R±0.1	S±0.10	f	YBC252 YBC251	YBG105 YBG102 YB9320 YBG205 YBG202 YBG302	YD101 YD201
 ZTHS0504-MG	0.4	5	0,10-0,25		● ●	
 ZTKS0608-MG	0.8	6	0,13-0,30		○ ●	

● Ex stock ○ On demand

HC¹ Coated carbide
HW Uncoated carbide

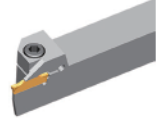
C

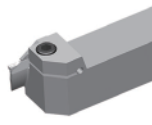
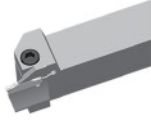
Drilling

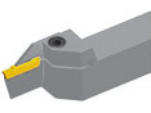
Tool holders					
QE*S*/R/L	QZ**+QE**	QF*S*LL-H	QF*S*RR-H	QF*S*/R/L-L	QF*S*/R/L-H
					
A379	A383	A389	A389	A392	A393

D

Technical Information

E



Index

System code > A352











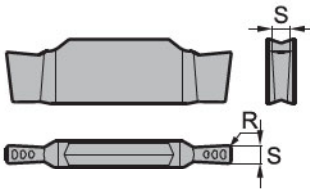



Grade selection > A350

Technical info > A447

Cutting data > A402

-  Ideal machining conditions
-  Normal machining conditions
-  Unfavourable machining conditions

Parting inserts

Parting & grooving insert (double sided)					HC ¹ (CVD)		HC ¹ (PVD)				HW				
					P										
					M										
					K										
					N										
					S										
					H										
ISO	La max	S±0.025	R±0.05	f	YBC252	YBC251	YBG105	YBG102	YB9320	YBG205	YBG202	YBG302	YD101	YD201	
ZTCD01002-EG	2.6	1	0.2	0,02-0,04								○			
ZTCD010500-EG	2.6	1.05	0	0,02-0,04								○			
ZTCD011502-EG	2.6	1.15	0.2	0,02-0,04								○			
ZTCD01202-EG	2.6	1.2	0.2	0,02-0,04								○			
ZTCD01302-EG	2.6	1.3	0.2	0,02-0,04								○			
ZTCD013802-EG	2.6	1.38	0.2	0,02-0,04								○			
ZTCD01402-EG	2.6	1.4	0.2	0,02-0,04								○			
ZTCD01500-EG	2.6	1.5	0	0,02-0,04								○			
ZTCD01502-EG	2.6	1.5	0.2	0,02-0,04								○			
ZTCD01503-EG	2.6	1.5	0.3	0,02-0,04								○			
ZTCD015503-EG	2.6	1.55	0.3	0,02-0,04								○			
ZTCD01602-EG	2.6	1.6	0.2	0,02-0,04								●			
ZTCD01702-EG	3.4	1.7	0.2	0,02-0,08								○			
ZTCD017503-EG	3.4	1.75	0.3	0,02-0,08								○			
ZTCD017602-EG	3.4	1.76	0.2	0,02-0,08								○			
ZTCD01802-EG	3.4	1.8	0.2	0,02-0,08								○			
ZTCD018502-EG	3.4	1.85	0.2	0,02-0,08								○			
ZTCD02000-EG	3.4	2	0	0,02-0,08								○			
ZTCD02002-EG	3.4	2	0.2	0,02-0,08								●			
ZTCD02003-EG	3.4	2	0.3	0,02-0,08								○			
ZTCD020503-EG	3.4	2.05	0.3	0,02-0,08								○			
ZTCD021502-EG	3.4	2.15	0.2	0,02-0,08								○			
ZTCD022503-EG	3.4	2.25	0.3	0,02-0,08								○			
ZTCD02302-EG	3.4	2.3	0.2	0,03-0,11								○			
ZTCD02303-EG	3.4	2.3	0.3	0,03-0,11								○			
ZTCD02402-EG	3.4	2.4	0.2	0,03-0,11								○			

● Ex stock ○ On demand

HC¹ Coated carbide
HW Uncoated carbide

Tool holders

QECD

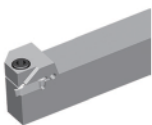

A380

System code > A352

Grade selection > A350

Technical info > A447

Cutting data > A402



A

Turning

B

Milling

C

Drilling

D

Technical Information

E

Index

A

Turning

B

Milling

C



Drilling

D











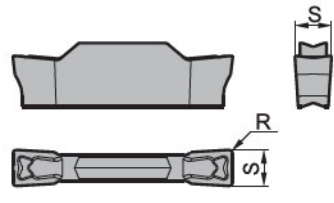





Technical Information

E

Index

-  Ideal machining conditions
-  Normal machining conditions
-  Unfavourable machining conditions



Parting inserts

Parting & grooving insert (double sided)						HC ¹ (CVD)		HC ¹ (PVD)			HW							
						P												
						M												
						K												
						N												
						S												
						H												
ISO	La max	S±0.025	R±0.05	f	YBC252	YBC251	YBG105	YBG102	YBG320	YBG205	YBG202	YBG302	YD101	YD201				
ZTED0247020-EG	17	2.47	0.2	0,03-0,11								○						
ZTED02502-EG	17	2.5	0.2	0,03-0,11								○						
ZTED026502-EG	17	2.65	0.2	0,03-0,11								○						
ZTED02702-EG	17	2.7	0.2	0,03-0,11								○						
ZTED02703-EG	17	2.7	0.3	0,03-0,11								○						
ZTED02802-EG	17	2.8	0.2	0,04-0,13								○						
ZTED02803-EG	17	2.8	0.3	0,04-0,13								○						
ZTED02804-EG	17	2.8	0.4	0,04-0,13								○						
ZTED02903-EG	17	2.9	0.3	0,04-0,13								○						
ZTFD03001-EG	17	3	0.1	0,04-0,13								○						
ZTFD03002-EG	17	3	0.2	0,04-0,13								○						
ZTFD03003-EG	17	3	0.3	0,04-0,13								○						
ZTFD03005-EG	17	3	0.5	0,04-0,13								○						
ZTFD031802-EG	17	3.18	0.2	0,04-0,13								○						
ZTFD03203-EG	17	3.2	0.3	0,04-0,13								○						
ZTFD0325024-EG	17	3.25	0.24	0,04-0,13								○						
ZTFD03302-EG	17	3.3	0.2	0,04-0,13								○	○					
ZTFD03303-EG	17	3.3	0.3	0,04-0,13								○						
ZTFD03403-EG	17	3.4	0.3	0,04-0,13								○						
ZTFD035-EG	17	3.5	0	0,04-0,13								○						
ZTFD03602-EG	17	3.6	0.2	0,04-0,13								○						
ZTGD039602-EG	22	3.96	0.2	0,07-0,18								○						
ZTGD04002-EG	22	4	0.2	0,07-0,18		○						○	○					
ZTGD04003-EG	22	4	0.3	0,07-0,18								○						
ZTGD04004-EG	22	4	0.4	0,07-0,18								○						
ZTGD04008-EG	22	4	0.8	0,07-0,18								○						
ZTGD0423010-EG	22	4.23	0.1	0,07-0,18								○						
ZTGD04503-EG	22	4.5	0.3	0,07-0,18								○						
ZTGD04505-EG	22	4.8	0.5	0,07-0,18								○						
ZTGD04803-EG	22	4.8	0.3	0,1-0,24								○						
ZTGD04805-EG	22	4.8	0.5	0,1-0,24								○						
ZTHD05003-EG	22	5	0.3	0,1-0,24								○						
ZTHD05004-EG	22	5	0.4	0,1-0,24								○						
ZTHD05008-EG	22	5	0.8	0,1-0,24								○						











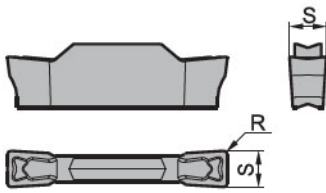













● Ex stock ○ On demand

HC¹ Coated carbide
HW Uncoated carbide







-  Ideal machining conditions
-  Normal machining conditions
-  Unfavourable machining conditions

Parting inserts

Parting & grooving insert (double sided)						HC ¹ (CVD)		HC ¹ (PVD)			HW				
	P														
	M														
	K														
	N														
	S														
	H														
ISO	La max	S±0.025	R±0.05	f	YBC252	YBC251		YBG105	YBG102	YB9320	YBG205	YBG202	YBG302	YD101	YD201
ZTHD05003-EG	22	5	0.3	0,1-0,24											
ZTHD05004-EG	22	5	0.4	0,1-0,24											
ZTHD05008-EG	22	5	0.8	0,1-0,24											
ZTHD05012-EG	22	5	0.12	0,1-0,24											
ZTHD05202-EG	22	5.2	0.2	0,1-0,24											
ZTHD052503-EG	22	5.25	0.3	0,1-0,24											
ZTHD05403-EG	22	5.4	0.3	0,1-0,24											
ZTHD05508-EG	22	5.5	0.8	0,1-0,24											
ZTHD055603-EG	22	5.56	0.3	0,1-0,24											
ZTKD06004-EG	22	6	0.4	0,12-0,29											
ZTKD06504-EG	22	6.5	0.4	0,12-0,29											

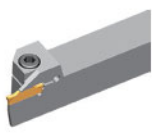
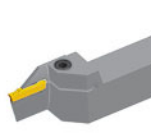
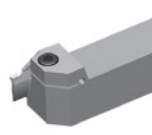
● Ex stock ○ On demand

HC¹ Coated carbide
HW Uncoated carbide

Tool holders					
QE*D*R/L	QF*D*R/L-H	QF*D*LL-H	QF*D*RR-H	QF*D*R/L-L	C***-Q*DR/L
					
A377	A385	A387	A387	A390	A395

System code > A352

Grade selection > A350

Technical info > A447

Cutting data > A402



A

Turning

B

Milling

C

Drilling

D

Technical Information



E











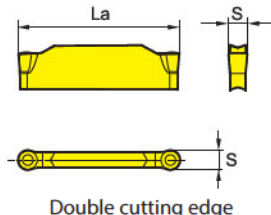





Index

A

Turning



Parting inserts

-  Ideal machining conditions
-  Normal machining conditions
-  Unfavourable machining conditions

Parting & grooving insert (double sided)				HC ¹ (CVD)		HC ¹ (PVD)					HW	
 <p>Double cutting edge</p>	P											
	M											
	K											
	N											
	S											
	H											

B

Milling







ISO	La max	S±0.10	f	YBC252		YBC251		YBG					YD		
				YBC252	YBC251	YBG105	YBG102	YBG9320	YBG205	YBG202	YBG302	YD101	YD201		
 ZRED025-MG	17.5	2.5	0,03-0,11												
ZRFD03-MG	17	3	0,04-0,14												
ZRGD04-MG	21	4	0,07-0,2												
ZRHD05-MG	20	5	0,1-0,24												
ZRKD06-MG	19	6	0,12-0,29												

● Ex stock ○ On demand

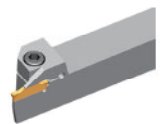
HC¹ Coated carbide
HW Uncoated carbide

C

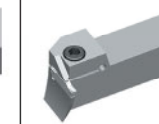
Drilling

Tool holders						
QE*D*R/L	QX*D*	QF*D*R/L-H	QF*D*LL-H	QF*D*RR-H	QF*D*R/L-L	C*X-Q*DR/L
						
A377	A381	A385	A387	A387	A390	A394

D

Technical Information

C***-Q*DR/L

A395

E

Index



- Ideal machining conditions
- Normal machining conditions
- Unfavourable machining conditions

Parting inserts

Parting & grooving insert (double sided)					HC ¹ (CVD)		HC ¹ (PVD)			HW
<p>Double cutting edge</p>	P									
	M									
	K									
	N									
	S									
	H									
ISO	La max	S±0.025	f	YBC252 YBC251			YBG105 YBG102 YB9320 YBG205 YBG202 YBG302		YD101 YD201	
	ZRFD03-EG	17	3	0,04-0,14				● ○		
	ZRGD04-EG	21	4	0,07-0,2				● ○		
	ZRHD05-EG	20	5	0,1-0,24				● ○		
	ZRKD06-EG	19	6	0,12-0,29				○		

● Ex stock ○ On demand

HC¹ Coated carbide
HW Uncoated carbide

Tool holders

QE*D*R/L	QX*D*	QF*D*R/L-H	QF*D*LL-H	QF*D*RR-H	QF*D*R/L-L	C*X-Q*DR/L
A377	A381	A385	A387	A387	A390	A394

C*-Q*DR/L**



System code > A352

Grade selection > A350

Technical info > A447

Cutting data > A402



A

Turning

B

Milling

C

Drilling

D

Technical Information



E











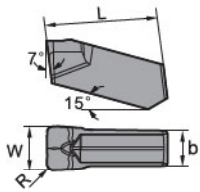





Index

A

Turning









Parting inserts

-  Ideal machining conditions
-  Normal machining conditions
-  Unfavourable machining conditions

Parting & grooving insert (single sided)							HC ¹ (CVD)		HC ¹ (PVD)					HW	
	P														
	M														
	K														
	N														
	S														
	H														

B

Milling

ISO	R±0.1	W±0.05	b	L	f	YBC252 YBC251		YBG105 YBG102 YB9320 YBG205 YBG202 YBG302					YD101 YD201		
 ZIMF304N-NM	0.4	3	2.4	15.3	0,04-0,11										
ZIMF406N-NM	0.6	4	3.2	15.3	0,07-0,16										
ZIMF506N-NM	0.6	5	4	15.3	0,1-0,2										
ZIMF608N-NM	0.8	6	4	15.3	0,12-0,23										

● Ex stock ○ On demand

HC¹ Coated carbide
HW Uncoated carbide

C

Drilling

Tool holders

QE*S*R/L-N



A382

D

Technical Information

E



Index

System code > A352











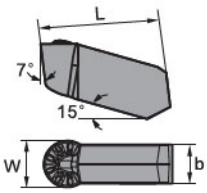





Grade selection > A350

Technical info > A447

Cutting data > A402

-  Ideal machining conditions
-  Normal machining conditions
-  Unfavourable machining conditions

Parting inserts

Parting & grooving insert (single sided)					HC ¹ (CVD)		HC ¹ (PVD)			HW	
	P										
	M										
	K										
	N										
	S										
	H										
ISO	W±0.05	b	L	f	YBC252 YBC251		YBG105 YBG102 YB9320 YBG205 YBG202 YBG302				YD101 YD201
	ZIGQ3N-NM	3	2.4	15.3	0,04-0,11			● ○			
	ZIGQ4N-NM	4	3.2	15.3	0,07-0,16			● ○			
	ZIGQ5N-NM	5	4	15.3	0,1-0,2			● ○			
	ZIGQ6N-NM	6	5	15.3	0,13-0,24			● ○			

● Ex stock ○ On demand

HC¹ Coated carbide
HW Uncoated carbide

Tool holders

QE*S*R/L-N



A382

System code > A352

Grade selection > A350

Technical info > A447

Cutting data > A402



A

Turning

B

Milling

C

Drilling

D

Technical Information



E











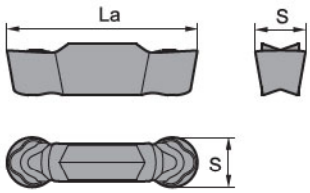





Index

A

Turning

Parting inserts

-  Ideal machining conditions
-  Normal machining conditions
-  Unfavourable machining conditions

Parting & grooving insert (double sided)					HC ¹ (CVD)		HC ¹ (PVD)					HW	
	P												
	M												
	K												
	N												
	S												
	H												

B

Milling



ISO	La max	S±0.025	f	YBC252		YBC251		YBG105					YD101		
ZRKD06-LH	19	6	0,12-0,23												○
ZRLD08-LH	22	8	0,14-0,26												●

● Ex stock ○ On demand

HC¹ Coated carbide
HW Uncoated carbide

C

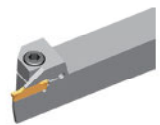
Drilling

Tool holders		
QE*D*R/L	C*X-Q*DR/L	C***-Q*DR/L
		
A377	A394	A395



D

Technical Information











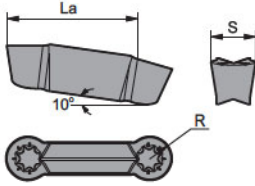







E

Index



-  Ideal machining conditions
-  Normal machining conditions
-  Unfavourable machining conditions

Parting inserts

Parting & grooving insert (double sided)					HC ¹ (CVD)		HC ¹ (PVD)			HW	
	P										
	M										
	K										
	N										
	S										
	H										
ISO	La max	S±0.025	f	YBC252 YBC251			YBG105 YBG102 YB9320 YBG205 YBG202 YBG302			YD101 YD201	
	ZILD08-LC	22	8	0,14-0,26						○ ○	

● Ex stock ○ On demand

HC¹ Coated carbide
HW Uncoated carbide

A

Turning

B

Milling

C

Drilling

D

Technical Information

E

Index

System code > A352

Grade selection > A350

Technical info > A447

Cutting data > A402



A



QC 22 R 300 – R 03

1 2 3 4 5 6

Turning

B

Milling

Series	Cutting edge length [mm]		Cutting direction	
	Code	I.C	Code	Description
	11	6,35	R	 Right
	16	9,525	L	 Left
	22	12,70		

1

2

3

C

Drilling

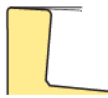
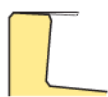
Groove width [mm]		Edge shape		Radius/Chamfer [mm]	
Code	Description	Code	Description	Code	Description
050	0,50	R	 Radius	005	0,05
100	1,00	C	 Chamfer	02	0,2
...	...			03	0,3
480	4,80			04	0,4

4

5

6

D

Technical Information



Triangular inserts (round edge)

QC 22 R 300 – R

1 2 3 4 5

E

Index

Series	Cutting edge length [mm]		Cutting direction		Groove width [mm]		Round
	Code	I.C	Code	Description	Code	Description	
	11	6,35	R	 Right	050	0,50	
	16	9,525	L	 Left	100	1,00	
	22	12,70			
					480	4,80	

1

2

3

4

5

Parting inserts

- Ideal machining conditions
- ⊗ Normal machining conditions
- ⊗ Unfavourable machining conditions

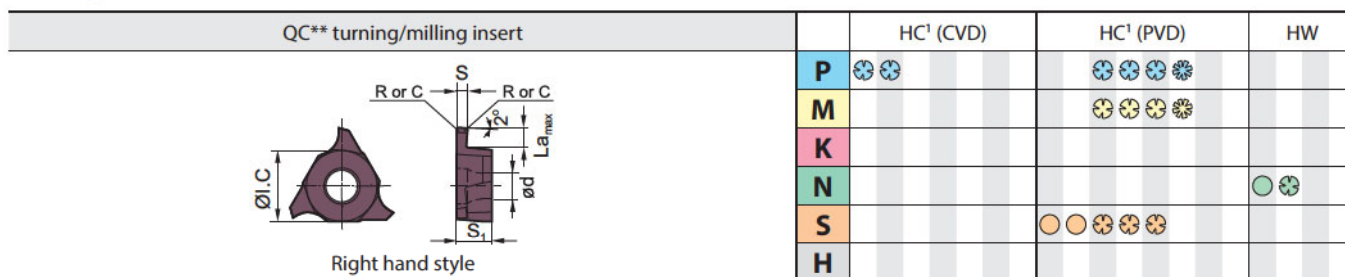

ISO	La max	S±0.025	R/C	ØI.C	S1	ød	f	HC ¹ (CVD)		HC ¹ (PVD)					HW	
								YBC252	YBC251	YBG105	YBG102	YB9320	YBG205	YBG202	YBG302	YD101
QC11R120-R02	1.5	1.2	0.2	6.35	3.18	2.8	0,02-0,03					●				
QC11L120-R02	1.5	1.2	0.2	6.35	3.18	2.8	0,02-0,03					●				
QC11R125-R02	1.5	1.25	0.2	6.35	3.18	2.8	0,02-0,03					●				
QC11L125-R02	1.5	1.25	0.2	6.35	3.18	2.8	0,02-0,03					●				
QC11R145-R02	1.5	1.45	0.2	6.35	3.18	2.8	0,02-0,05					●				
QC11L145-R02	1.5	1.45	0.2	6.35	3.18	2.8	0,02-0,05					●				
QC11R150-R02	1.5	1.5	0.2	6.35	3.18	2.8	0,02-0,05					●				
QC11L150-R02	1.5	1.5	0.2	6.35	3.18	2.8	0,02-0,05					●				
QC11R200-R02	2	2	0.2	6.35	3.18	2.8	0,02-0,06					●				
QC11L200-R02	2	2	0.2	6.35	3.18	2.8	0,02-0,06					●				
QC11R225-R02	2	2.25	0.2	6.35	3.18	2.8	0,02-0,06					○				
QC11L225-R02	2	2.25	0.2	6.35	3.18	2.8	0,02-0,06					○				
QC16R075-R01	2	0.75	0.1	9.525	3.18	4.4	0,02-0,03					○				
QC16L075-R01	2	0.75	0.1	9.525	3.18	4.4	0,02-0,03					○				
QC16R080-R01	2	0.8	0.1	9.525	3.18	4.4	0,02-0,03					○				
QC16R095-R01	2	0.95	0.1	9.525	3.18	4.4	0,02-0,03					○				
QC16L095-R01	2	0.95	0.1	9.525	3.18	4.4	0,02-0,03					○				
QC16L100-R01	2	1	0.1	9.525	3.18	4.4	0,02-0,03					○				
QC16R110-R01	2	1.1	0.1	9.525	3.18	4.4	0,02-0,03					○ ○				
QC16L110-R01	2	1.1	0.1	9.525	3.18	4.4	0,02-0,03					● ○				
QC16R115-R04	2	1.15	0.4	9.525	3.18	4.4	0,02-0,03					○				
QC16R120-R01	2	1.2	0.1	9.525	3.18	4.4	0,02-0,03					○				
QC16L120-R01	2	1.2	0.1	9.525	3.18	4.4	0,02-0,03					○				
QC16R125-R02	2	1.25	0.2	9.525	3.18	4.4	0,02-0,03					○ ○				
QC16L125-R02	2	1.25	0.2	9.525	3.18	4.4	0,02-0,03					●				
QC16R130-R02	2	1.3	0.2	9.525	3.18	4.4	0,02-0,06					○				
QC16L130-R02	2	1.3	0.2	9.525	3.18	4.4	0,02-0,06					○				
QC16R140-R02	2	1.4	0.2	9.525	3.18	4.4	0,02-0,06					○				
QC16R145-R02	2	1.45	0.2	9.525	3.18	4.4	0,02-0,06					●				
QC16L145-R02	2	1.45	0.2	9.525	3.18	4.4	0,02-0,06					●				
QC16R150-R02	2	1.5	0.2	9.525	3.18	4.4	0,02-0,06					●				
QC16L150-R02	2	1.5	0.2	9.525	3.18	4.4	0,02-0,06					○				
QC16R160-R02	2	1.6	0.2	9.525	3.18	4.4	0,02-0,06					●				
QC16L160-R02	2	1.6	0.2	9.525	3.18	4.4	0,02-0,06					●				

● Ex stock ○ On demand

HC¹ Coated carbide
HW Uncoated carbide



A
Turning

B
Milling

C
Drilling

D
Technical Information

E
Index

A

Turning

B

Milling

C



Drilling

D











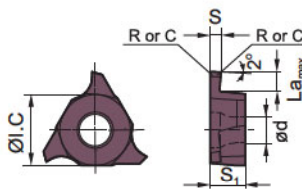









Technical Information

E

Index

-  Ideal machining conditions
-  Normal machining conditions
-  Unfavourable machining conditions

Parting inserts

QC** turning/milling insert								HC ¹ (CVD)		HC ¹ (PVD)					HW	
 <p>Right hand style</p>	P															
	M															
	K															
	N															
	S															
H																

ISO	La max	S±0.025	R/C	ØI.C	S1	ød	f	YBC252	YBC251	YBG105	YBG102	YBG9320	YBG205	YBG202	YBG302	YD101	YD201
QC16R165-R02	2	1.65	0.2	9.525	3.18	4.4	0,02-0,06						○				
QC16L165-R02	2	1.65	0.2	9.525	3.18	4.4	0,02-0,06						○				
QC16R170-R02	2	1.7	0.2	9.525	3.18	4.4	0,02-0,06						○				
QC16L170-R02	2	1.7	0.2	9.525	3.18	4.4	0,02-0,06						○				
QC16R175-R02	2	1.75	0.2	9.525	3.18	4.4	0,02-0,07						●				
QC16L175-R02	2	1.75	0.2	9.525	3.18	4.4	0,02-0,06						○				
QC16R180-R02	2	1.8	0.2	9.525	3.18	4.4	0,02-0,07						○				
QC16R185-R02	2.5	1.85	0.2	9.525	3.18	4.4	0,02-0,07						●				
QC16L185-R02	2.5	1.85	0.2	9.525	3.18	4.4	0,02-0,07						○				
QC16R200-R02	2.5	2	0.2	9.525	3.18	4.4	0,02-0,07						●				
QC16L200-R02	2.5	2	0.2	9.525	3.18	4.4	0,02-0,07						●				
QC16L210-R02	2.5	2.1	0.2	9.525	3.18	4.4	0,02-0,07						○				
QC16L210-R05	2.5	2.1	0.5	9.525	3.18	4.4	0,02-0,07						○				
QC16R220-R02	2.5	2.2	0.2	9.525	3.18	4.4	0,02-0,07						○				
QC16L220-R02	2.5	2.2	0.2	9.525	3.18	4.4	0,02-0,07						○				
QC16R250-R02	2.5	2.5	0.2	9.525	3.18	4.4	0,02-0,08						● ○				
QC16L250-R02	2.5	2.5	0.2	9.525	3.18	4.4	0,02-0,08						●				
QC16R300-R02	3	3	0.2	9.525	3.18	4.4	0,03-0,11						●				
QC16L300-R02	3	3	0.2	9.525	3.18	4.4	0,03-0,11						●				
QC22L100-R02	2	1	0.2	12.7	4.76	5.5	0,02-0,03						○				
QC22R125-R02	2	1.25	0.2	12.7	4.76	5.5	0,02-0,03						●				
QC22L125-R02	2	1.25	0.2	12.7	4.76	5.5	0,02-0,03						○				
QC22R145-R02	2	1.45	0.2	12.7	4.76	5.5	0,02-0,06						○				
QC22L145-R02	2	1.45	0.2	12.7	4.76	5.5	0,02-0,06						○				
QC22R150-R02	3.5	1.5	0.2	12.7	4.76	5.5	0,02-0,06						○				
QC22L150-R02	3.5	1.5	0.2	12.7	4.76	5.5	0,02-0,06						○				
QC22R175-R02	3.5	1.75	0.2	12.7	4.76	5.5	0,02-0,06						●				
QC22L175-R02	3.5	1.75	0.2	12.7	4.76	5.5	0,02-0,06						○				
QC22R185-R02	3.5	1.85	0.2	12.7	4.76	5.5	0,02-0,07						●				
QC22L185-R02	3.5	1.85	0.2	12.7	4.76	5.5	0,02-0,07						○				
QC22R195-R02	3.5	1.95	0.2	12.7	4.76	5.5	0,02-0,07						○				
QC22R200-R02	3.5	2	0.2	12.7	4.76	5.5	0,02-0,07						○				
QC22L200-R02	3.5	2	0.2	12.7	4.76	5.5	0,02-0,07						○				
QC22R225-R02	3.5	2.25	0.2	12.7	4.76	5.5	0,02-0,07						○				

● Ex stock ○ On demand

HC¹ Coated carbide
HW Uncoated carbide

System code > A352

Grade selection > A350

Technical info > A447

Cutting data > A402

- Ideal machining conditions
- Normal machining conditions
- Unfavourable machining conditions

Parting inserts

QC** turning/milling insert

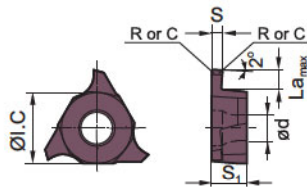

Right hand style

QC** turning/milling insert								HC ¹ (CVD)		HC ¹ (PVD)			HW				
								P	M	K	N	S	H				
ISO	La max	S±0.025	R/C	ØI.C	S1	ød	f	YBC252	YBC251	YBG105	YBG102	YB9320	YBG205	YBG202	YBG302	YD101	YD201
QC22R230-R02	3.5	2.3	0.2	12.7	4.76	5.5	0,02-0,07										
QC22L230-R02	3.5	2.3	0.2	12.7	4.76	5.5	0,02-0,07										
QC22R250-R03	4	2.5	0.3	12.7	4.76	5.5	0,02-0,08										
QC22L250-R03	4	2.5	0.3	12.7	4.76	5.5	0,02-0,08										
QC22R265-R03	4	2.65	0.3	12.7	4.76	5.5	0,02-0,08										
QC22L265-R03	4	2.65	0.3	12.7	4.76	5.5	0,02-0,08										
QC22R280-R03	4	2.8	0.3	12.7	4.76	5.5	0,02-0,08										
QC22L280-R03	4	2.8	0.3	12.7	4.76	5.5	0,02-0,08										
QC22R300-R03	4	3	0.3	12.7	4.76	5.5	0,03-0,11										
QC22L300-R03	4	3	0.3	12.7	4.76	5.5	0,03-0,11										
QC22R320-R03	4	3.2	0.3	12.7	4.76	5.5	0,03-0,11										
QC22L320-R03	4	3.2	0.3	12.7	4.76	5.5	0,03-0,11										
QC22R330-R03	4	3.3	0.3	12.7	4.76	5.5	0,03-0,11										
QC22L330-R03	4	3.3	0.3	12.7	4.76	5.5	0,03-0,11										
QC22R350-R03	5	3.5	0.3	12.7	4.76	5.5	0,05-0,13										
QC22L350-R03	5	3.5	0.3	12.7	4.76	5.5	0,05-0,13										
QC22R400-R04	5	4	0.4	12.7	4.76	5.5	0,05-0,14										
QC22L400-R04	5	4	0.4	12.7	4.76	5.5	0,05-0,14										
QC22R430-R04	5	4.3	0.4	12.7	4.76	5.5	0,05-0,14										
QC22L430-R04	5	4.3	0.4	12.7	4.76	5.5	0,05-0,14										
QC22R450-R04	5	4.5	0.4	12.7	4.76	5.5	0,06-0,18										
QC22L450-R04	5	4.5	0.4	12.7	4.76	5.5	0,06-0,18										
QC22R480-R04	5	4.8	0.4	12.7	5.06	5.5	0,06-0,18										
QC22L480-R04	5	4.8	0.4	12.7	5.06	5.5	0,08-0,2										

● Ex stock ○ On demand

HC¹ Coated carbide
HW Uncoated carbide

Tool holders

GQCR/L	S***-QC**R/L
A399	A400

System code > A352

Grade selection > A350

Technical info > A447



Cutting data > A402











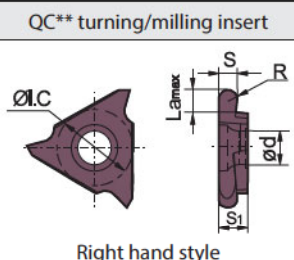







A

Turning

Parting inserts

-  Ideal machining conditions
-  Normal machining conditions
-  Unfavourable machining conditions



QC** turning/milling insert		HC ¹ (CVD)	HC ¹ (PVD)	HW
P			   	
M			   	
K				
N				 
S			   	
H				

B

Milling

ISO	La max	S±0.025	R/C	ØI.C	S1	ød	f	YBC252	YBC251	YBG105	YBG102	YBG9320	YBG205	YBG202	YBG302	YD101	YD201
QC16R100R	2	1	0.5	12.7	3.18	4.4	0,02-0,03						○				
QC16R120R	2	1.2	0.6	12.7	3.18	4.4	0,02-0,03						○				
QC16R150R	2	1.5	0.75	12.7	3.18	4.4	0,02-0,06						○				
QC16R200R	2.5	2	1	12.7	3.18	4.4	0,02-0,07						●				
QC16L200R	2.5	2	1	12.7	3.18	4.4	0,02-0,07						○				
QC16R250R	2.5	2.5	1.25	12.7	3.18	4.4	0,02-0,08						○				
QC16L280R	2.5	2.8	1.4	12.7	3.18	4.4	0,02-0,08						○				
QC16R300R	2.5	3	1.5	12.7	3.18	4.4	0,03-0,11						●				
QC16L300R	2.5	3	1.5	12.7	3.18	4.4	0,03-0,11						● ○				
QC22R100R	2	1	0.5	12.7	4.76	5.5	0,02-0,03						●				
QC22L100R	2	1	0.5	12.7	4.76	5.5	0,02-0,03						○ ●				
QC22R150R	3.5	1.5	0.75	12.7	4.76	5.5	0,02-0,06						●				
QC22L150R	3.5	1.5	0.75	12.7	4.76	5.5	0,02-0,06						● ○				
QC22R170R	3.5	1.7	0.85	12.7	4.76	5.5	0,02-0,06						○				
QC22R200R	3.5	2	1	12.7	4.76	5.5	0,02-0,07						○				
QC22L200R	3.5	2	1	12.7	4.76	5.5	0,02-0,07						○				
QC22R250R	4	2.5	1.25	12.7	4.76	5.5	0,02-0,08						●				
QC22L250R	4	2.5	1.25	12.7	4.76	5.5	0,02-0,08						●				
QC22R300R	4	3	1.5	12.7	4.76	5.5	0,03-0,11						●				
QC22L300R	4	3	1.5	12.7	4.76	5.5	0,03-0,11						●				
QC22R320R	4	3.2	1.6	12.7	4.76	5.5	0,03-0,11						○				
QC22R400R	5	4	2	12.7	4.76	5.5	0,05-0,14						●				
QC22L400R	5	4	2	12.7	4.76	5.5	0,05-0,14						●				

C

Drilling



D



Technical Information

● Ex stock ○ On demand

HC¹ Coated carbide
HW Uncoated carbide

E

Index

Tool holders	
QOCR/L	S***-QC**R/L
	
A399	A400

System code > A352

Grade selection > A350

Technical info > A447

Cutting data > A402

External tool holders

Q F G D 2525 R 22 (S) – (130) (H)

1

2

3

4

5

6

7

8

9

10

Holder for parting & grooving
--

1

Application	
Code	Description
E	External machining
F	Axial machining

2

Insert seat size [mm]	
Holder/cutting width	
Code	Description
B	2,0
E	2,5
F	3,0
G	4,0
H	5,0
K	6,0
L	8,0

3

No. of cutting edges	
Code	Description
S	Single
D	Double

4

Cross section of holder [mm] x [mm]
--

5

Type	
Code	Description
R	Right
L	Left
N	Right and left

6

Max. cutting depth [mm]

7

Extra	
Code	Description
S	Strengthened holder for deep cuts

8

Min. diameter of work piece for first axial grooving [mm]
--

9

Cutting head	
Code	Description
H	0°
L	90°

10

Boring bars

C 32 S – Q G D R 11 – 44

1

2

3

4

5

6

7

8

9

Clamping system

1

Diameter [mm]

2

Length [mm]	
Code	Description
Q	180
R	200
S	250
X	320

3

Holder for grooving

4

Insert seat size [mm]	
Holder/Cutting width	
Code	Description
B	2.0
E	2.5
F	3.0
G	4.0
H	5.0
K	6.0
L	8.0

5

No. of cutting edges	
Code	Description
S	Single
D	Double

6

Type	
Code	Description
R	Right
L	Left
N	Right and left

7

Max. cutting depth [mm]

8

Min. internal diameter of work piece [mm]
--

9

A

Turning

B

Milling

C

Drilling

D

Technical Information

E

Index

Blade

Q E G D 32 N

1 2 3 4 5 6

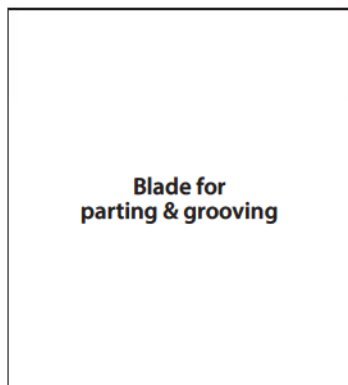

1

Application	
Code	Description
E	External machining

2

Insert seat size [mm]	
Holder/cutting width	
Code	Description
B	2,0
E	2,5
F	3,0
G	4,0
H	5,0
K	6,0
L	8,0

3

No. of cutting edges	
Code	Description
S	Single
D	Double

4

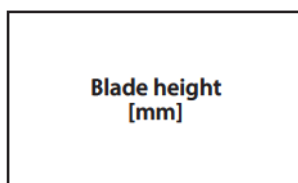

5

Type	
Code	Description
R	Right
L	Left
N	Right and left

6

Clamping block

QZ S 32 32

1 2 3 4

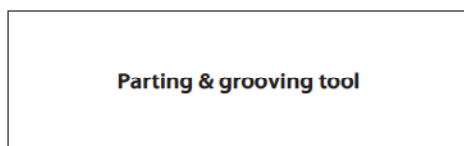

1

No. of cutting edges	
Code	Description
S	Single
D	Double

2

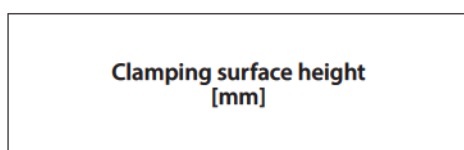

3

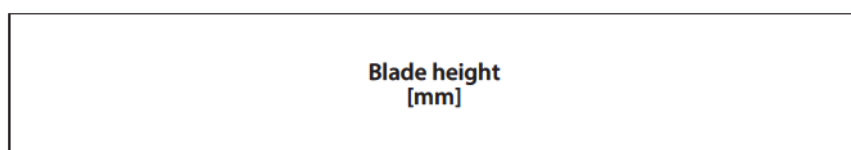

4

Parting & grooving tool holder (external)

QE**R/L

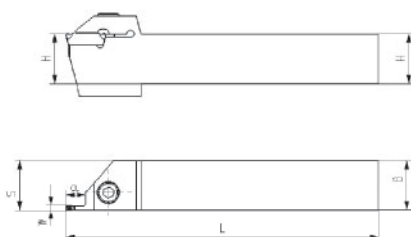
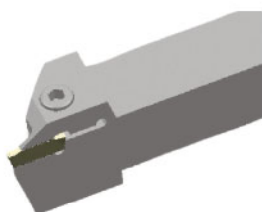

Article	*	Stock		Dimensions [mm]					Inserts
		R	L	HxB	L	S	W	ar _{max}	
QEED1616R/L10	●	●	16x16	125	15	2.5	10	Z*ED**	
QEED1616R/L17	●	●	16x16	125	15	2.5	17	Z*ED**	
QEED2020R/L17	●	●	20x20	125	19	2.5	17	Z*ED**	
QEED2020R/L10	●	●	20x20	150	10	2.5	10	Z*ED**	
QEED2525R/L10	●	●	25x25	150	19	2.5	10	Z*ED**	
QEED2525R/L17	●	●	25x25	150	19	2.5	17	Z*ED**	
QEGD2020R/L13	●	●	20x20	140	18.5	4	13	Z*GD**	
QEGD2020R/L22	●	●	20x20	140	18.5	4	22	Z*GD**	
QEGD2525R/L13	●	●	25x25	150	23.5	4	13	Z*GD**	
QEGD2525R/L22	●	●	25x25	150	23.5	4	22	Z*GD**	
QEGD3232R/L13	●	●	32x32	170	30.5	4	13	Z*GD**	
QEGD3232R/L22	●	●	32x32	170	30.5	4	22	Z*GD**	
QEHD2525R/L13	●	●	25x25	150	23	5	13	Z*HD**	
QEHD2525R/L22	●	●	25x25	150	23	5	22	Z*HD**	
QEHD3232R/L13	●	●	32x32	170	30	5	13	Z*HD**	
QEHD3232R/L22	●	●	32x32	170	30	5	22	Z*HD**	
QEKD2525R/L13	●	●	25x25	150	22.6	6	13	Z*KD**	
QEKD2525R/L22	●	●	25x25	150	22.6	6	22	Z*KD**	
QEKD3232R/L13	●	●	32x32	170	29.6	6	13	Z*KD**	
QEKD3232R/L22	●	●	32x32	170	29.6	6	22	Z*KD**	

● Ex stock ○ On demand

* With internal cooling

System code > A376

Grade selection > A350

Technical info > A447



Cutting data > A402



A

Parting & grooving tool holder (external)

Spare parts

	Insert	Z*BD**	Z*ED**	Z*ED**	Z*FD**	Z*FD**	Z*GD**	Z*HD**	Z*KD**
	H	16-20	16	20-32	16	20-32	20-32	20-32	20-32
	Screw	GB70-85-M5x16 (4.0 Nm)	GB70-85-M5x20 (4.0 Nm)	GB70-85-M6x20 (7.0 Nm)	GB70-85-M5x20 (4.0 Nm)	GB70-85-M6x20 (7.0 Nm)	GB70-85-M6x20 (7.0 Nm)	GB70-85-M6x20 (7.0 Nm)	GB70-85-M6x20 (7.0 Nm)
	Wrench	WH40L	WH40L	WH50L	WH40L	WH50L	WH50L	WH50L	WH50L

Turning

B

Insert

						
A353	A354	A356	A357	A359	A362	A363

Milling

C



A366

Drilling

D

Technical Information

E

Index

System code > A376

Grade selection > A350

Technical info > A447

Cutting data > A402

Parting & grooving tool holder (external)

QE*SN30

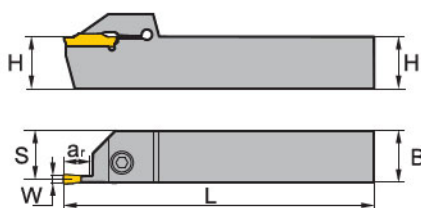
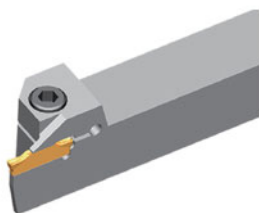

Article	*	Stock	Dimensions [mm]					Inserts
			HxB	L	S	W	ar _{max}	
QEHS2525N30	●	25x25	150	12.5	5	30	Z*HS**	
QEHS3232N30	●	32x32	170	16	5	30	Z*HS**	
QEKS2525N30	○	25x25	150	12.5	6	30	Z*Ks**	
QEKS3232N30	○	32x32	170	16	6	30	Z*Ks**	

● Ex stock ○ On demand

* With internal cooling

Spare parts			
	Insert	Z*HS**	Z*Ks**
	H	25-32	25-32
	Screw	GB70-85-M6x20 (7.0 Nm)	GB70-85-M6x20 (7.0 Nm)
	Wrench	WH50L	WH50L

Insert	
A355	A358

System code > A376

Grade selection > A350

Technical info > A447

Cutting data > A402

Parting & grooving tool holder (external)

QECDR/L

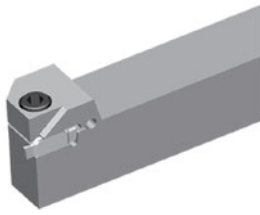

Right hand style

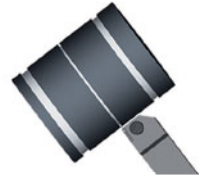
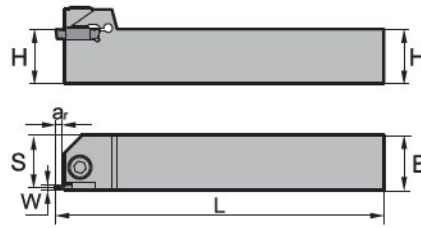



Article	*	Stock		Dimensions [mm]					Inserts
		R	L	HxB	L	S	W	ar _{max}	
QECD1616R/L025		○	○	16x16	125	14.75		2.5	Z*CD**
QECD2020R/L025		○	○	20x20	125	18.75		2.5	Z*CD**
QECD2525R/L025		○	○	25x25	150	23.75		2.5	Z*CD**

● Ex stock ○ On demand

* With internal cooling

Spare parts

	Insert	Z*CD**	Z*CD**
	H	16	20-32
	Screw	GB70-85-M5x20 (4.0 Nm)	GB70-85-M6x20 (7.0 Nm)
	Wrench	WH40L	WH50L

Insert



A359

System code > A376

Grade selection > A350

Technical info > A447

Cutting data > A402

Parting & grooving tool holder (external)

QX*DR/L

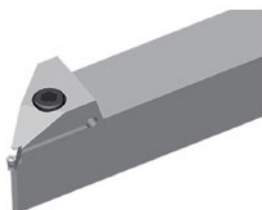

Right hand style

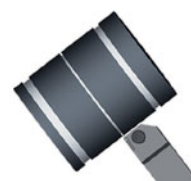
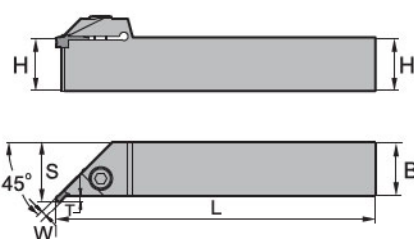

Article	*	Stock		Dimensions [mm]					Inserts
		R	L	HxB	L	S	W	ar _{max}	
QXFD2020R/L03-45	○	○		20x20	125	23	3	3	Z*FD**
QXFD2525R/L03-45	●	●		25x25	150	28	3	3	Z*FD**
QXFD3232R/L03-45	○	○		32x32	170	35	3	3	Z*FD**
QXGD2020R/L03-45	○	○		20x20	125	23	4	3	Z*GD**
QXGD2525R/L03-45	○	○		25x25	150	28	4	3	Z*GD**
QXGD3232R/L03-45	○	○		32x32	170	35	4	3	Z*GD**
QXHD2020R/L04-45	○	○		20x20	125	24	5	4	Z*HD**
QXHD2525R/L04-45	○	○		25x25	150	29	5	4	Z*HD**
QXHD3232R/L04-45	○	○		32x32	170	36	5	4	Z*HD**
QXKD2020R/L04-45	○	○		20x20	125	24	6	4	Z*KD**
QXKD2525R/L04-45	○	○		25x25	150	29	6	4	Z*KD**
QXKD3232R/L04-45	○	○		32x32	170	36	6	4	Z*KD**

● Ex stock ○ On demand

* With internal cooling

Spare parts

	Insert	Z*FD**	Z*GD**	Z*HD**	Z*KD**
	H	20-32	20-32	20-32	20-32
	Screw	GB70-85-M6x20 (7.0 Nm)	GB70-85-M6x20 (7.0 Nm)	GB70-85-M6x20 (7.0 Nm)	GB70-85-M6x20 (7.0 Nm)
	Wrench	WH50L	WH50L	WH50L	WH50L

Insert

A362	A363

Parting & grooving tool holder (external)

QE*SR/L

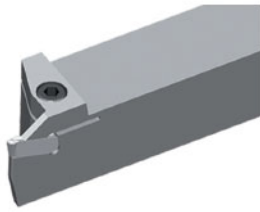

Right hand style

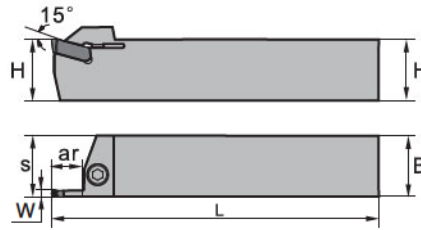

A

Turning

B

Milling

C

Drilling

D

Technical Information

E

Index

Article	*	Stock		Dimensions [mm]					Inserts
		R	L	HxB	L	S	W	ar _{max}	
QEFS2525R/L12-3N	○	○		25x25	150	25.3	3	12	ZI**
QEGS2525R/L12-4N	○	○		25x25	150	25.3	4	12	ZI**
QEHS2525R/L12-5N	○	○		25x25	150	25.4	5	12	ZI**
QEKs2525R/L12-6N	○	○		25x25	150	25.4	6	12	ZI**
QEFS3232R/L22-3N	○	○		32x32	170	32.3	3	22	ZI**
QEGS3232R/L22-4N	○	○		32x32	170	32.3	4	22	ZI**
QEHS3232R/L22-5N	○	○		32x32	170	32.4	5	22	ZI**
QEKs3232R/L22-6N	○	○		32x32	170	32.4	6	22	ZI**

● Ex stock ○ On demand

* With internal cooling

Spare parts		
	Insert	ZI**
	H	25-32
	Screw	GB70-85-M6x20 (7.0 Nm)
	Wrench	WH50L

Insert	
A364	A365

System code > A376

Grade selection > A350

Technical info > A447

Cutting data > A402

Parting blade for external machining

QE*S**N

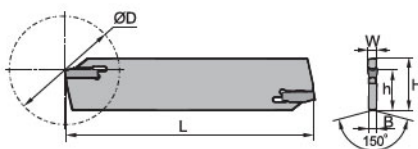
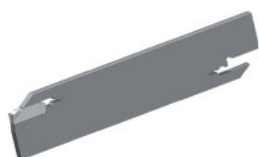

Article	*	Stock	Dimensions [mm]						Inserts
			H	L	h	B	W	ØDmax	
QEES26N		●	26	110	19	2	2.5	60	ZPES**
QEES32N		●	32	150	24.6	2	2.5	100	ZPES**
QEFS26N		●	26	110	19	2.4	3	60	ZPFS**
QEFS32N		●	32	150	24.6	2.4	3	100	ZPFS**
QEGS26N		●	26	110	19	3.2	4	70	ZPGS**
QEGS32N		●	32	150	24.6	3.2	4	120	ZPGS**
QEHS26N		●	26	110	19	4	5	70	ZPHS**
QEHS32N		●	32	150	24.6	4	5	120	ZPHS**
QEKs26N		●	26	110	19	5	6	70	ZPKS**
QEKs32N		●	32	150	24.6	5	6	120	ZPKS**

● Ex stock ○ On demand

* With internal cooling

Spare parts						
	Insert	ZPES**	ZPFS**	ZPGS**	ZPHS**	ZPKS**
	H	26-32	26-32	26-32	26-32	26-32
	Wrench	W50RL	W50RL	W50RL	W50RL	W50RL

Insert	
A355	A358

System code > A376

Grade selection > A350

Technical info > A447

Cutting data > A402

Clamping block (external)

QZS*

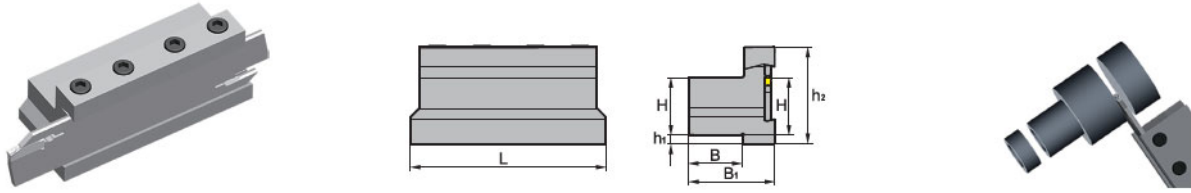

Article	*	Stock	Dimensions [mm]						Inserts
			H	L	h ₁	h ₂	B	B ₁	
QZS2026	●	●	20	86	10	46.6	19	38	QE**26
QZS2526	●	●	25	86	5	46.6	23	42	QE**26
QZS3226	○	○	32	86	3	51.6	30	48	QE**26
QZS2032	●	●	20	110	13	50	19	38	QE**32
QZS2532	●	●	25	110	8	50	23	42	QE**32
QZS3232	●	●	32	110	5	54	30	48	QE**32

● Ex stock ○ On demand

* With internal cooling

Spare parts

	Insert	QE**26	QE**32
	H	20-32	20-32
	Clamp	QZC26	QZC32
	Screw	GB70-85-M6x20 (7.0 Nm)	GB70-85-M6x20 (7.0 Nm)
	Wrench	W50RL	W50RL

A

Turning

B

Milling

C

Drilling

D

Technical Information

E

Index

Parting & grooving tool holder (axial)

QF**R/L



Left hand style

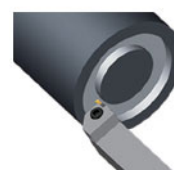
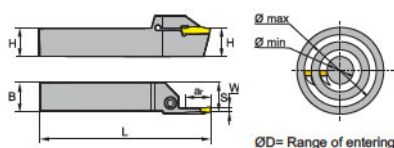

Article	*	Stock		Dimensions [mm]						Inserts
		R	L	HxB	L	S	W	ar _{max}	ØD (min-max)	
QFFD2020R/L7-48H	○ ○	○ ○	20x20	150	21	3	7	7	48-66	Z*FD**
QFFD2020R/L7-60H	○ ○	○ ○	20x20	150	21	3	7	7	60-80	Z*FD**
QFFD2020R/L7-74H	○ ○	○ ○	20x20	150	21	3	7	7	74-110	Z*FD**
QFFD2020R/L7-100H	○ ○	○ ○	20x20	150	21	3	7	7	100-150	Z*FD**
QFFD2020R/L10-48H	○ ○	○ ○	20x20	150	21	3	10	10	48-66	Z*FD**
QFFD2020R/L10-60H	○ ○	○ ○	20x20	150	21	3	10	10	60-80	Z*FD**
QFFD2020R/L10-74H	○ ○	○ ○	20x20	150	21	3	10	10	74-110	Z*FD**
QFFD2020R/L10-100H	○ ○	○ ○	20x20	150	21	3	10	10	100-150	Z*FD**
QFFD2525R/L10-48H	● ●	● ●	25x25	150	26	3	10	10	48-66	Z*FD**
QFFD2525R/L10-60H	● ●	● ●	25x25	150	26	3	10	10	60-80	Z*FD**
QFFD2525R/L10-74H	● ●	● ●	25x25	150	26	3	10	10	74-110	Z*FD**
QFFD2525R/L10-100H	● ●	● ●	25x25	150	26	3	10	10	100-150	Z*FD**
QFFD2525R/L17-48H	● ●	● ●	25x25	150	26	3	17	17	48-66	Z*FD**
QFFD2525R/L17-60H	● ●	● ●	25x25	150	26	3	17	17	60-80	Z*FD**
QFFD2525R/L17-74H	● ●	● ●	25x25	150	26	3	17	17	74-110	Z*FD**
QFFD2525R/L17-100H	● ●	● ●	25x25	150	26	3	17	17	100-150	Z*FD**
QFGD2020R/L10-52H	○ ○	○ ○	20x20	150	19	4	10	10	52-72	Z*GD**
QFGD2020R/L10-64H	○ ○	○ ○	20x20	150	19	4	10	10	64-100	Z*GD**
QFGD2020R/L10-90H	○ ○	○ ○	20x20	150	19	4	10	10	90-140	Z*GD**
QFGD2020R/L10-130H	○ ○	○ ○	20x20	150	19	4	10	10	130-230	Z*GD**
QFGD2020R/L15-52H	○ ○	○ ○	20x20	150	19	4	15	15	52-72	Z*GD**
QFGD2020R/L15-64H	○ ○	○ ○	20x20	150	19	4	15	15	64-100	Z*GD**
QFGD2020R/L15-90H	○ ○	○ ○	20x20	150	19	4	15	15	90-140	Z*GD**
QFGD2020R/L15-130H	○ ○	○ ○	20x20	150	19	4	15	15	130-230	Z*GD**
QFGD2525R/L13-52H	● ●	● ●	25x25	150	24	4	13	13	52-72	Z*GD**
QFGD2525R/L13-64H	● ●	● ●	25x25	150	24	4	13	13	64-100	Z*GD**
QFGD2525R/L13-90H	● ●	● ●	25x25	150	24	4	13	13	90-140	Z*GD**
QFGD2525R/L13-130H	● ●	● ●	25x25	150	24	4	13	13	130-230	Z*GD**
QFGD2525R/L22-52H	● ●	● ●	25x25	150	24	4	22	22	52-72	Z*GD**
QFGD2525R/L22-64H	● ●	● ●	25x25	150	24	4	22	22	64-100	Z*GD**
QFGD2525R/L22-90H	● ●	● ●	25x25	150	24	4	22	22	90-140	Z*GD**
QFGD2525R/L22-130H	● ●	● ●	25x25	150	24	4	22	22	130-230	Z*GD**
QFHD2525R/L13-58H	● ●	● ●	25x25	150	23.5	5	13	13	58-96	Z*HD**
QFHD2525R/L13-86H	● ●	● ●	25x25	150	23.5	5	13	13	86-140	Z*HD**
QFHD2525R/L13-130H	● ●	● ●	25x25	150	23.5	5	13	13	130-200	Z*HD**
QFHD2525R/L13-185H	● ●	● ●	25x25	150	23.5	5	13	13	185-400	Z*HD**

System code > A376

Grade selection > A350

Technical info > A447

Cutting data > A402



A

Turning

B

Milling

C

Drilling

D

Technical Information

E

Index

A

Turning



Article	*	Stock		Dimensions [mm]						Inserts 
		R	L	HxB	L	S	W	ar _{max}	ØD (min-max)	
QFHD2525R/L22-58H	●	●	25x25	150	23.5	5	22	58-96	Z*HD**	
QFHD2525R/L22-86H	●	●	25x25	150	23.5	5	22	86-140	Z*HD**	
QFHD2525R/L22-130H	●	●	25x25	150	23.5	5	22	130-200	Z*HD**	
QFHD2525R/L22-185H	●	●	25x25	150	23.5	5	22	185-400	Z*HD**	
QFKD2525R/L13-60H	●	●	25x25	150	23	6	13	60-100	Z*KD**	
QFKD2525R/L13-88H	○	●	25x25	150	23	6	13	88-180	Z*KD**	
QFKD2525R/L13-160H	●	●	25x25	150	23	6	13	160-400	Z*KD**	
QFKD2525R/L22-60H	●	●	25x25	150	23	6	22	60-100	Z*KD**	
QFKD2525R/L22-88H	●	●	25x25	150	23	6	22	88-180	Z*KD**	
QFKD2525R/L22-160H	●	●	25x25	150	23	6	22	160-400	Z*KD**	

● Ex stock ○ On demand

* With internal cooling

B

Milling

Spare parts					
	Insert	Z*FD**	Z*GD**	Z*HD**	Z*KD**
	H	20-25	20-25	20-25	20-25
	Screw	GB70-85-M6x20 (7.0 Nm)	GB70-85-M6x20 (7.0 Nm)	GB70-85-M6x20 (7.0 Nm)	GB70-85-M6x20 (7.0 Nm)
	Wrench	W50RL	W50RL	W50RL	W50RL

C

Drilling

Insert					
					
A353	A354	A357	A359	A362	A363

D

Technical Information

E

Index

System code > A376

Grade selection > A350

Technical info > A447

Cutting data > A402

Parting & grooving tool holder (axial)

QF**RR/LL

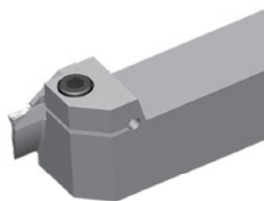

LL Version

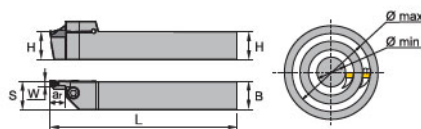

Article	*	Stock		Dimensions [mm]						Inserts
		R	L	HxB	L	S	W	ar _{max}	ØD (min-max)	
QFFD2020LL10-48H		○		20x20	150	21	3	10	48-66	Z*FD**
QFFD2020RR10-48H		○		20x20	150	21	3	10	48-66	Z*FD**
QFFD2020RR10-60H		○		20x20	150	21	3	10	60-80	Z*FD**
QFFD2020RR10-74H		○		20x20	150	21	3	10	74-110	Z*FD**
QFFD2525LL10-48H		●		25x25	150	26	3	10	48-66	Z*FD**
QFFD2525RR10-48H		○		25x25	150	26	3	10	48-66	Z*FD**
QFFD2525LL10-60H		○		25x25	150	26	3	10	60-80	Z*FD**
QFFD2525RR10-60H		○		25x25	150	26	3	10	60-80	Z*FD**
QFFD2525LL10-74H		○		25x25	150	26	3	10	74-110	Z*FD**
QFFD2525RR10-74H		○		25x25	150	26	3	10	74-110	Z*FD**
QFFD2525LL10-100H		○		25x25	150	26	3	10	100-150	Z*FD**
QFFD2525RR10-100H		○		25x25	150	26	3	10	100-150	Z*FD**
QFFD2525LL17-48H		●		25x25	150	26	3	17	48-66	Z*FD**
QFFD2525RR17-48H		○		25x25	150	26	3	17	48-66	Z*FD**
QFFD2525LL17-60H		○		25x25	150	26	3	17	60-80	Z*FD**
QFFD2525RR17-60H		○		25x25	150	26	3	17	60-80	Z*FD**
QFFD2525LL17-74H		○		25x25	150	26	3	17	74-110	Z*FD**
QFFD2525RR17-74H		○		25x25	150	26	3	17	74-110	Z*FD**
QFFD2525LL17-100H		○		25x25	150	26	3	17	100-150	Z*FD**
QFFD2525RR17-100H		○		25x25	150	26	3	17	100-150	Z*FD**
QFGD2020LL10-52H		○		20x20	150	21	4	10	52-72	Z*GD**
QFGD2020RR10-52H		○		20x20	150	21	4	10	52-72	Z*GD**
QFGD2020LL15-52H		○		20x20	150	26	4	15	52-72	Z*GD**
QFGD2020LL15-90H		○		20x20	150	26	4	15	90-140	Z*GD**
QFGD2020RR15-90H		○		20x20	150	26	4	15	90-140	Z*GD**
QFGD2020RR15-130H		○		20x20	150	26	4	15	130-230	Z*GD**
QFGD2525RR13-52H		●		25x25	150	21	4	13	52-72	Z*GD**
QFGD2525LL13-64H		●		25x25	150	21	4	13	64-100	Z*GD**
QFGD2525RR13-64H		○		25x25	150	21	4	13	64-100	Z*GD**
QFGD2525LL13-130H		●		25x25	150	26	4	13	130-230	Z*GD**
QFGD2525RR13-130H		○		25x25	150	21	4	13	130-230	Z*GD**
QFGD2525LL22-52H		○		25x25	150	26	4	22	52-72	Z*GD**
QFGD2525RR22-52H		○		25x25	150	26	4	22	52-72	Z*GD**
QFGD2525LL22-64H		○		25x25	150	26	4	22	64-100	Z*GD**
QFGD2525RR22-64H		○		25x25	150	26	4	22	64-100	Z*GD**

System code > A376

Grade selection > A350

Technical info > A447

Cutting data > A402



A

Turning

B

Milling

C

Drilling

D

Technical Information

E

Index

A

Turning

B

Milling

C

Drilling

D



Technical Information







E

Index

Article	*	Stock		Dimensions [mm]						Inserts
		R	L	HxB	L	S	W	ar _{max}	ØD (min-max)	
QFGD2525LL22-90H	○			25x25	150	26	4	22	90-140	Z*GD**
QFGD2525RR22-90H	○			25x25	150	26	4	22	90-140	Z*GD**
QFGD2525LL22-130H	○			25x25	150	26	4	22	130-230	Z*GD**
QFGD2525RR22-130H	●			25x25	150	26	4	22	130-230	Z*GD**
QFHD2525LL13-130H	○			25x25	150	26	5	13	130-200	Z*HD**
QFHD2525RR13-130H	○			25x25	150	26	5	13	130-200	Z*HD**
QFHD2525RR13-185H	○			25x25	150	26	5	13	185-400	Z*HD**
QFHD2525LL22-58H	●			25x25	150	26	5	22	58-96	Z*HD**
QFHD2525RR22-58H	●			25x25	150	26	5	22	58-96	Z*HD**
QFHD2525RR22-86H	○			25x25	150	26	5	22	86-140	Z*HD**
QFHD2525LL22-130H	○			25x25	150	26	5	22	130-200	Z*HD**
QFHD2525RR22-130H	●			25x25	150	26	5	22	130-200	Z*HD**
QFHD2525LL22-185H	○			25x25	150	26	5	22	185-400	Z*HD**
QFHD2525RR22-185H	○			25x25	150	26	5	22	185-400	Z*HD**
QFKD2525RR13-60H	○			25x25	150	26	6	13	60-100	Z*KD**
QFKD2525RR13-88H	○			25x25	150	26	6	13	88-180	Z*KD**
QFKD2525LL22-88H	○			25x25	150	26	6	22	88-180	Z*KD**
QFKD2525RR22-88H	○			25x25	150	26	6	22	88-180	Z*KD**
QFKD2525LL22-160H	●			25x25	150	26	6	22	160-400	Z*KD**
QFKD2525RR22-160H	○			25x25	150	26	6	22	160-400	Z*KD**

● Ex stock ○ On demand
* With internal cooling

Spare parts					
	Insert	Z*FD**	Z*GD**	Z*HD**	Z*KD**
	H	20-25	20-25	20-25	20-25
	Screw	GB70-85-M6x20 (7.0 Nm)	GB70-85-M6x20 (7.0 Nm)	GB70-85-M6x20 (7.0 Nm)	GB70-85-M6x20 (7.0 Nm)
	Wrench	W50RL	W50RL	W50RL	W50RL

Insert					
					
A353	A354	A357	A359	A362	A363



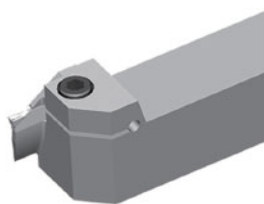

Parting & grooving tool holder (axial)

QF*SRR/LL



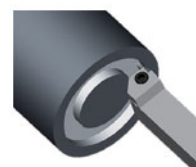
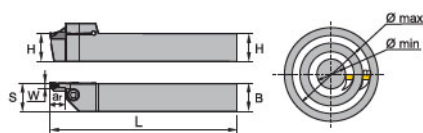

LL Version





Article	*	Stock		Dimensions [mm]						Inserts
		R	L	HxB	L	S	W	ar _{max}	ØD (min-max)	
QFHS2525LL30-185H	●			25x25	150	26	5	30	185-400	Z*HS**
QFHS2525SRR30-185H	○			25x25	150	26	5	30	185-400	Z*HS**
QFKS2525SRR30-160H	○			25x25	150	26	6	30	160-400	Z*KS**

● Ex stock ○ On demand

* With internal cooling

Spare parts			
	Insert	Z*HS**	Z*KS**
	H	25	25
	Screw	GB70-85-M6x20 (7.0 Nm)	GB70-85-M6x20 (7.0 Nm)
	Wrench	W50RL	W50RL

Insert	
	
A355	A358

System code > A376

Grade selection > A350

Technical info > A447

Cutting data > A402

Parting & grooving tool holder (axial)

QF*DR/L

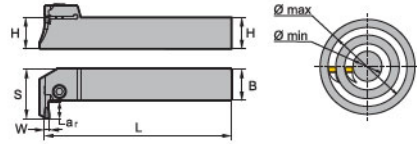
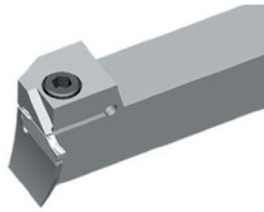

Right hand style

Article	*	Stock		Dimensions [mm]						Inserts
		R	L	HxB	L	S	W	ar _{max}	ØD (min-max)	
QFFD2020R/L7-74L		○		20x20	150	28.5	3	7	74-110	
QFFD2020R/L10-48L		○	○	20x20	150	31.5	3	10	48-66	Z*FD**
QFGD2020R/L10-52L		○	○	20x20	150	31.5	4	10	52-72	Z*GD**
QFFD2020R/L10-60L		●	○	20x20	150	31.5	3	10	60-80	Z*FD**
QFFD2020R/L10-74L		●	○	20x20	150	31.5	3	10	74-110	Z*FD**
QFGD2020R/L10-90L		●	○	20x20	150	31.5	4	10	90-140	Z*GD**
QFFD2020R/L10-100L		○	○	20x20	150	31.5	3	10	100-150	Z*FD**
QFGD2020R/L10-130L		●		20x20	150	31.5	4	10	130-230	
QFGD2020R/L15-52L		○	○	20x20	150	36.5	4	15	52-72	Z*GD**
QFGD2020R/L15-64L		○		20x20	150	36.5	4	15	64-100	
QFGD2020R/L15-90L		○		20x20	150	36.5	4	15	90-140	
QFGD2020R/L15-130L		○		20x20	150	36.5	4	15	130-230	
QFFD2525R/L10-48L		●	●	25x25	150	36.5	3	10	48-66	Z*FD**
QFFD2525R/L10-60L		●	○	25x25	150	36.5	3	10	60-80	Z*FD**
QFFD2525R/L10-74L		○	○	25x25	150	36.5	3	10	74-110	Z*FD**
QFFD2525R/L10-100L		○	○	25x25	150	36.5	3	10	100-150	Z*FD**
QFGD2525R/L13-52L		○	○	25x25	150	39.5	4	13	52-72	Z*GD**
QFKD2525R/L13-60L		○	○	25x25	150	39.5	6	13	60-100	Z*KD**
QFGD2525R/L13-64L		○	●	25x25	150	39.5	4	13	64-100	Z*GD**
QFGD2525R/L13-90L		○	○	25x25	150	39.5	4	13	90-140	Z*GD**
QFGD2525R/L13-130L		○	○	25x25	150	39.5	4	13	130-230	Z*GD**
QFFD2525R/L17-48L		○	○	25x25	150	43.5	3	17	48-66	Z*FD**
QFFD2525R/L17-60L		○	○	25x25	150	43.5	3	17	60-80	Z*FD**
QFFD2525R/L17-74L		○	○	25x25	150	43.5	3	17	74-110	Z*FD**
QFFD2525R/L17-100L		●	○	25x25	150	43.5	3	17	100-150	Z*FD**
QFGD2525R/L22-52L		○	○	25x25	150	48.5	4	22	52-72	Z*GD**
QFKD2525R/L22-60L		○	●	25x25	150	48.5	6	22	60-100	Z*KD**
QFGD2525R/L22-64L		○	○	25x25	150	48.5	4	22	64-100	Z*GD**
QFKD2525R/L22-88L		○	●	25x25	150	48.5	6	22	88-180	Z*KD**
QFGD2525R/L22-90L		○	○	25x25	150	48.5	4	22	90-140	Z*GD**
QFGD2525R/L22-130L		●	○	25x25	150	48.5	4	22	130-230	Z*GD**
QFHD2525R/L13-58L		○		25x25	150	39.5	5	13	58-96	Z*HD**
QFHD2525R/L13-86L		●		25x25	150	39.5	5	13	86-140	Z*HD**
QFHD2525R/L13-130L		○	○	25x25	150	39.5	5	13	130-200	Z*HD**
QFHD2525R/L13-185L		○		25x25	150	39.5	5	13	185-400	Z*HD**
QFHD2525R/L22-58L		○	○	25x25	150	48.5	5	22	58-96	Z*HD**

System code > A376

Grade selection > A350



Technical info > A447





Cutting data > A402

Article	*	Stock		Dimensions [mm]						Inserts
		R	L	HxB	L	S	W	ar _{max}	ØD (min-max)	
QFHD2525R/L22-86L		○	○	25x25	150	48.5	5	22	86-140	Z*HD**
QFHD2525R/L22-130L		○	○	25x25	150	48.5	5	22	130-200	Z*HD**
QFHD2525R/L22-185L		○	○	25x25	150	48.5	5	22	185-400	Z*HD**
QFKD2525R/L13-88L			○	25x25	150	39.5	6	13	88-180	Z*KD**

● Ex stock ○ On demand

* With internal cooling

Spare parts					
	Insert	Z*FD**	Z*GD**	Z*HD**	Z*KD**
	H	20-25	20-25	20-25	20-25
	Screw	GB70-85-M6x20 (7.0 Nm)	GB70-85-M6x20 (7.0 Nm)	GB70-85-M6x20 (7.0 Nm)	GB70-85-M6x20 (7.0 Nm)
	Wrench	W50RL	W50RL	W50RL	W50RL

Insert					
					
A353	A354	A357	A359	A362	A363

System code > A376

Grade selection > A350

Technical info > A447

Cutting data > A402

Parting & grooving tool holder (axial)

QFHSDR/L

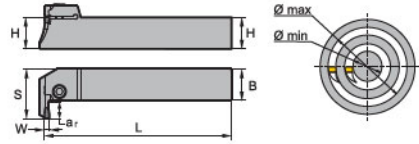
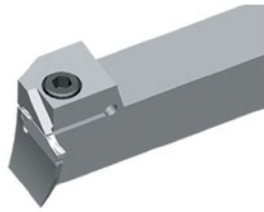

Right hand style

Article	*	Stock		Dimensions [mm]						Inserts
		R	L	HxB	L	S	W	ar _{max}	ØD (min-max)	
QFHS2525R/L30-185L		○	○	25x25	150	56.5	5	30	185-400	Z*HS**

● Ex stock ○ On demand

* With internal cooling

Spare parts

	Insert	Z*HS**
	H	25
	Screw	GB70-85-M6x20 (7.0 Nm)
	Wrench	W50RL

Insert

A355	A358

System code > A376

Grade selection > A350

Technical info > A447

Cutting data > A402

Parting & grooving tool holder (axial)

QF**R/L



Left hand style

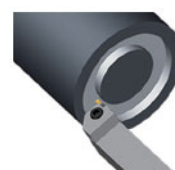
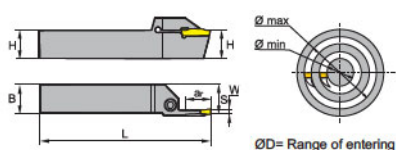

Article	*	Stock		Dimensions [mm]						Inserts
		R	L	HxB	L	S	W	ar _{max}	ØD (min-max)	
QFHS2525R/L30-185H	●	●		25x25	150	23.5	5	30	185-400	Z*HS**
QFKS2525R/L30-160H	●	●		25x25	150	23	6	30	160-400	Z*KS**

● Ex stock ○ On demand

* With internal cooling

Spare parts

	Insert	Z*HS**	Z*KS**
	H	25	25
	Screw	GB70-85-M6x20 (7.0 Nm)	GB70-85-M6x20 (7.0 Nm)
	Wrench	W50RL	W50RL

Insert

A355	A358

System code > A376

Grade selection > A350

Technical info > A447

Cutting data > A402

Parting & grooving tool holder (external)

C40X-Q*DR/L

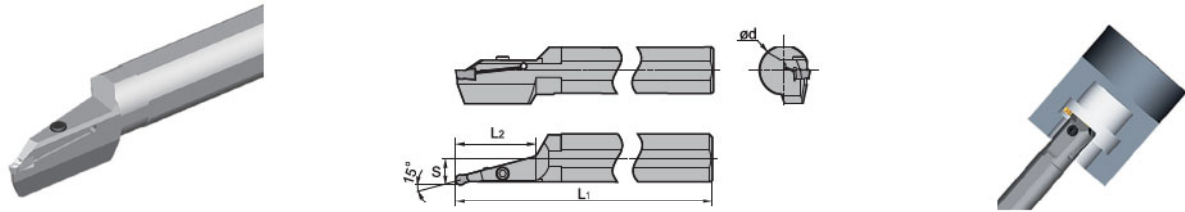

Right hand style

Article	*	Stock		Dimensions [mm]					Inserts
		R	L	ØD	ød	S	L ₁	L ₂	
C40X-QKDR/L60-15A		○	○	160	40	20	320	60	Z*KD**
C40X-QKDR/L75-15A		●		160	40	20	320	75	Z*KD**
C40X-QLDR/L65-15A		○	○	160	40	21	320	65	Z*LD**
C40X-QLDR/L80-15A		○	○	160	40	21	320	80	Z*LD**

● Ex stock ○ On demand

* With internal cooling

Spare parts			
	Insert	Z*KD**	Z*LD**
	ød	32-40	32-40
	Screw	GB70-85-M6x20 (7.0 Nm)	GB70-85-M6x20 (7.0 Nm)
	Wrench	WH50L	WH50L

Insert		
A362	A363	A366

System code > A376

Grade selection > A350

Technical info > A447

Cutting data > A402

Parting & grooving tool holder (internal)

C***-Q*DR/L

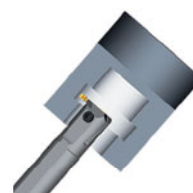
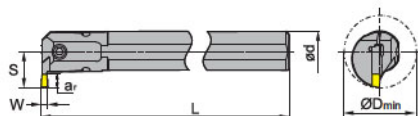

Article	*	Stock		Dimensions [mm]						Inserts
		R	L	ØDmin	ød	L	S	W	ar _{max}	
C16M-QBDR/L04-20	● ○	○		20	16	150	12	2	4	Z*BD**
C20Q-QEDR/L05-27	● ●			27	20	180	15.2	2.5	5	Z*ED**
C25R-QEDR/L07-33	● ●			33	25	200	20.3	2.5	7	Z*ED**
C32S-QEDR/L09-42	● ●			42	32	250	25.3	2.5	9	Z*ED**
C20Q-QFDR/L05-27	● ●			27	20	0	15.2	3	5	Z*FD**
C25R-QFDR/L07-33	● ●			33	25	200	20.3	3	7	Z*FD**
C32S-QFDR/L09-42	● ●			42	32	250	25.3	3	9	Z*FD**
C25R-QGDR/L08-35	● ●			35	25	200	21.5	4	8	Z*GD**
C32S-QGDR/L11-44	● ●			44	32	250	27.5	4	11	Z*GD**
C40T-QGDR/L13-54	● ●			5	40	300	33.5	4	13	Z*GD**
C25R-QHDR/L08-35	● ●			35	25	200	21.5	5	8	Z*HD**
C32S-QHDR/L11-44	● ●			44	32	250	27.5	5	11	Z*HD**
C40T-QHDR/L13-54	● ●			54	40	300	33.5	5	13	Z*HD**
C25R-QKDR/L08-35	○ ●			35	25	200	21.5	6	8	Z*KD**
C32S-QKDR/L11-44	● ●			44	32	250	27.5	6	11	Z*KD**
C40T-QKDR/L13-54	● ●			54	40	300	33.5	6	13	Z*KD**

● Ex stock ○ On demand

* With internal cooling

Spare parts

Insert	Screw													
	ød	Z*BD**	Z*ED**	Z*ED**	Z*ED**	Z*FD**	Z*FD**	Z*FD**	Z*GD**	Z*GD**	Z*HD**	Z*HD**	Z*KD**	Z*KD**
Screw	16	16	20	25	32-40	20	25	32-40	25	32-40	25	32-40	25	32-40
	GB70-85-M5x10 (4.0 Nm)	GB70-85-M4x12 (2.6 Nm)	GB70-85-M5x16 (4.0 Nm)	GB70-85-M6x20 (7.0 Nm)	GB70-85-M4x12 (2.6 Nm)	GB70-85-M5x16 (4.0 Nm)	GB70-85-M6x20 (7.0 Nm)	GB70-85-M5x16 (4.0 Nm)	GB70-85-M6x20 (7.0 Nm)	GB70-85-M5x16 (4.0 Nm)	GB70-85-M6x20 (7.0 Nm)	GB70-85-M5x16 (4.0 Nm)	GB70-85-M6x20 (7.0 Nm)	GB70-85-M6x20 (7.0 Nm)
Wrench	WH40L	WH30L	WH40L	WH50L	WH30L	WH40L	WH50L	WH40L	WH50L	WH40L	WH50L	WH40L	WH50L	

System code > A376

Grade selection > A350

Technical info > A447

Cutting data > A402



A

Turning

B

Milling

C

Drilling

D



Technical Information

E

Index

Parting & grooving tool holder (internal)

Insert

						
A353	A354	A357	A359	A362	A363	A366

A

Turning

B

Milling

C

Drilling

D

Technical Information

E

Index

System code > A376

Grade selection > A350

Technical info > A447

Cutting data > A402

External tool holders – QC series

GQC R 20 20 K 22 – 15

1 2 3 4 5 6 7

Series	Type		Height [mm]		Width [mm]		Length [mm]	
	Code	Description	Code	Description	Code	Description	Code	Description
	R	Right	16	16	16	16	K	125
L	Left	20	20	20	20	M	150	
		25	25	25	25			

1 2 3 4 5

Cutting edge length [mm]	
Code	I.C
11	6,35
16	9,252
22	12,70

6

Cutting width range [mm]		
Code	Insert size	
15	0,5 ≤ S < 1,8 (QC16***)	1,0 ≤ S < 2,3 (QC22***)
25	1,8 ≤ S < 3,0 (QC16***)	2,3 ≤ S < 3,3 (QC22***)
35	–	3,3 ≤ S ≤ 4,8 (QC22***)

7

Boring bars – QC series

S 20 K – QC 16 15 R 25

1 2 3 4 5 6 7 8

Shank type	
Code	Material
S	Steel shank
C	Solid carbide shank
A	Solid carbide shank (IC)

1

Diameter [mm]	
Code	Description
16	16
20	20
25	25

2

Length [mm]	
Code	Description
H	100
K	125
M	150

3

Series	Cutting edge length [mm]	
	Code	I.C
	11	6,35
16	9,252	
22	12,70	

4

5

Cutting width range [mm]			
Code	Insert size		
15	0,5 ≤ S < 1,8 (QC11***)	0,5 ≤ S < 1,8 (QC16***)	1,0 ≤ S < 2,3 (QC22***)
25	1,8 ≤ S < 3,0 (QC11***)	1,8 ≤ S < 3,0 (QC16***)	2,3 ≤ S < 3,3 (QC22***)
35	–	–	3,3 ≤ S ≤ 4,8 (QC22***)

6

Cutting direction	
Code	Description
R	Right
L	Left

7

Starting diameter [mm]			
Code	∅	Code	∅
16	16	25	25
20	20	35	35

8

Grooving (external)

GQC**R/L

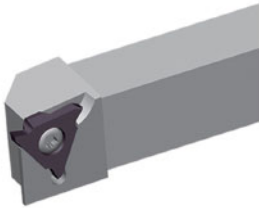

Right hand style

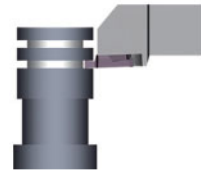
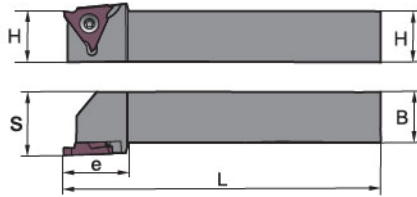



Article	*	Stock		Dimensions [mm]						Inserts
		R	L	H	L	S	e	B	Width	
GQCR/L1616K16-15	●	●	16	125	21	25.5	16	0.5-1.80	QC16R/L 050-180	
GQCR/L2020K16-15	○	●	20	125	25	25.5	20	0.5-1.80	QC16R/L 050-180	
GQCR/L2525M16-15	○	●	25	150	30	25.5	25	0.5-1.80	QC16R/L 050-180	
GQCR/L1616K16-25	●	●	16	125	21	25.5	16	1.8-3.0	QC16R/L 180-300	
GQCR/L2020K16-25	○	●	20	125	25	25.5	20	1.8-3.0	QC16R/L 180-300	
GQCR/L2525M16-25	○	●	25	150	30	25.5	25	1.8-3.0	QC16R/L 180-300	
GQCR/L2020K22-15	○	●	20	125	25	25.5	20	1.0-2.3	QC22R/L 100-230	
GQCR/L2525M22-15	○	●	25	150	30	25.5	25	1.0-2.3	QC22R/L 100-230	
GQCR/L2020K22-25	○	●	20	125	25	25.5	20	2.3-3.3	QC22R/L 230-330	
GQCR/L2525M22-25	○	●	25	150	30	25.5	25	2.3-3.3	QC22R/L 230-330	
GQCR/L2020K22-35	●	●	20	125	25	25.5	20	3.3-4.8	QC22R/L 330-480	
GQCR/L2525M22-35	●	●	25	150	30	25.5	25	3.3-4.8	QC22R/L 330-480	

● Ex stock ○ On demand

* With internal cooling

Spare parts

	Insert	QC16R/L 050-180	QC16R/L 180-300	QC22R/L 100-230	QC22R/L 230-330	QC22R/L 330-480
	Screw	I60M3.5x10 (2.7 Nm)	I60M3.5x10 (2.7 Nm)	I60M5x13 (6.7 Nm)	I60M5x13 (6.7 Nm)	I60M5x13 (6.7 Nm)
	Wrench (shim)	WT15IP	WT15IP	WT20IP	WT20IP	WT20IP

Insert



Medium Cut

A369

Grooving (internal)

S**-QC**R/L

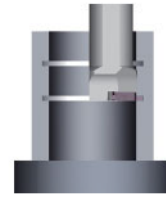
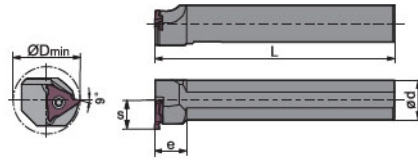

Right hand style

Article	*	Stock		Dimensions [mm]						Inserts
		R	L	ØDmin	ød	L	S	e	Width	
S16H-QC1115R/L20	●	●		21	16	100	11.5	12	0.5-1.80	QC11R/L 050-180
S20K-QC1115R/L16	●	●		16	20	125	11.1	40	0.5-1.80	QC11R/L 050-180
S16H-QC1125R/L20	●	●		21	16	100	11.5	12	1.8-3.0	QC11R/L 180-300
S20K-QC1125R/L16	○	○		16	20	125	11.1	40	1.8-3.0	QC11R/L 180-300
S20M-QC1615R/L25	○	●		26	20	150	12.5	15	0.5-1.80	QC16R/L 050-180
S20M-QC1625R/L25	●	●		26	20	150	12.5	15	1.8-3.0	QC16R/L 180-300
S25M-QC2215R/L35	●	●		35	25	150	18.2	15	1.0-2.3	QC22R/L 100-230
S25M-QC2225R/L35	●	●		35	25	150	18.2	20	2.3-3.3	QC22R/L 230-330
S25M-QC2235R/L35	○	●		35	25	150	18.2	20	3.3-4.8	QC22R/L 330-480

● Ex stock ○ On demand

* With internal cooling

Spare parts

	Insert	QC11R/L 050-180	QC11R/L 180-300	QC16R/L 050-180	QC16R/L 180-300	QC22R/L 100-230	QC22R/L 230-330	QC22R/L 330-480
		ød	16-20	16-20	20	20	25	25
	Screw	I60M2.5x6.5 (1.0 Nm)	I60M2.5x6.5 (1.0 Nm)	I60M3.5x10 (2.7 Nm)	I60M3.5x10 (2.7 Nm)	I60M5x13 (6.7 Nm)	I60M5x13 (6.7 Nm)	I60M5x13 (6.7 Nm)
	Wrench (shim)	WT07IP	WT07IP	WT15IP	WT15IP	WT20IP	WT20IP	WT20IP

Insert



Medium Cut

A369

System code > A376

Grade selection > A350

Technical info > A447

Cutting data > A402

Parting & grooving inserts

Material group	Composition / structure / heat treatment		Brinell hardness HB	Machining group	Starting values for cutting speed vc (m/min)			
					HC (CVD)		HC (PVD)	
					YBC252	YBG105	YB9320	
P Unalloyed steel	approx. 0,15 % C	annealed	125	1	190	200	190	
	approx. 0,45 % C	annealed	190	2	175	180	175	
	approx. 0,45 % C	tempered	250	3	145	150	145	
	approx. 0,75 % C	annealed	270	4	140	145	140	
	approx. 0,75 % C	tempered	300	5	135	140	135	
	Low-alloyed steel		annealed	180	6	170	180	170
			tempered	275	7	125	130	125
			tempered	300	8	115	120	115
		tempered	350	9	105	110	105	
High-alloyed steel and high-alloyed tool steel		annealed	200	10	125	130	125	
		hardened and tempered	325	11	95	100	95	
M Stainless steel	ferritic/martensitic	annealed	200	12	165	170	165	
	martensitic	tempered	240	13	135	140	135	
	austenitic	quench hardened	180	14	155	160	155	
	austenitic-ferritic		230	15	135	140	135	
K Grey cast iron Cast iron with spheroidal graphite Malleable cast iron	perlitic/ferritic		180	16	240	250	240	
		perlitic (martensitic)	260	17	185	190	185	
	ferritic		160	18	220	230	220	
		perlitic	250	19	165	170	165	
	ferritic		130	20	175	180	175	
		perlitic	230	21	165	170	165	
N Aluminium wrought alloys Cast aluminium alloys Copper and copper alloys (bronze/brass)	cannot be hardened		60	22				
	hardenable	hardened	100	23				
	≤ 12% Si, cannot be hardened		75	24				
		≤ 12% Si, hardenable	hardened	90	25			
		> 12% Si, cannot be hardened		130	26			
	machining steel, PB> 1%		110	27				
		CuZn, CuSnZn	90	28				
		CuSn, Pb-free copper, electrolytic copper	100	29				
S Heat-resistant alloys Titanium alloys	Fe-based alloys	annealed	200	30		100	95	
		hardened	280	31		50	50	
		annealed	250	32		80	80	
		hardened	350	33		70	70	
	Ni or Co bass	cast	320	34		70	70	
		pure titanium	R _m 400	35		150	145	
α and β alloys	hardened	R _m 1050	36		50	50		
H Hardened steel Hard cast iron Hardened cast iron		hardened and tempered	55 HRC	37				
		hardened and tempered	60 HRC	38				
		cast	400	39				
X Non-metallic materials		hardened and tempered	55 HRC	40				
	Thermoplasts			41				
	Thermosetting plastics			42				
	Plastic, glass-fibre reinforced GFRP			43				
	Plastic, carbon fibre reinforced CFRP			44				
Graphite			45					
Wood			46					

Note: The given cutting values are guide values, which were determined under ideal conditions. The values have to be adapted in individual cases. For examples of material for cutting tool groups view page D22.

A

Turning

B

Milling

C

Drilling

D

Technical Information

E

Index

